

An open tank 1.82m sq, weighs 3425 and contains 0.91 m of water. It is acted by an unbalanced force of 10400 N parallel to a pair of sides.

1. Find the acceleration of the tank

Ans. 3.092 m/s^2

2. What is the force acting on the side with the smallest depth?

Ans. 3465 N

3. What is the force acting on the side with greatest depth?

Ans. 12791 N

An unbalanced vertical force of 270 N upward accelerates a volume of 0.044 m^3 of water. If the water is 0.9 m deep in a cylindrical tank.

4. What is the acceleration of the tank?

Ans. 6.14 m/s^2

5. What is the pressure at the bottom of the tank in N/m^2 ?

Ans. 14355 N/m^2

6. Force acting on the bottom of tank in N?

Ans 702 N

An open vessel of water accelerates up a 27 degree plane at 2 m/s^2

7. What is the horizontal component of the acceleration?

Ans 1.78

8. What is the vertical component of the acceleration?

Ans 0.91

9. What is the angle that the water surface makes with the horizontal?

Ans 9.35 degrees

A $1 \times 1 \times 1 \text{ m}$ tank is 50% filled with oil ($\text{sg}=0.82$) and the remaining is water. When it is translated vertically upward at 5.10 m/s^2

10. Determine the pressure at the bottom.

Ans 13.57 KPa

11. Determine the velocity at the orifice 50 mm diam. located at the bottom of the tank.

Ans 5.20 m/s

12. Discharge if the coefficient of discharge C is equal to 0.6

Ans $0.0061 \text{ m}^3/\text{s}$

The tank shown is accelerated to the right at 10 m/s^2

See figure

13. Find the pressure at A

Ans 51.74 kPa

14. Find the pressure at B

Ans 76.26 kPa

15. Find the pressure at C

Ans = 0

An open cylindrical tank having a radius of 0.30 m and a height of 1.20 m. is filled with water at a depth of 0.90 m.

16. How fast will it be rotated about its vertical axis if half of its volume is spilled out?

Ans 178.34 rpm

17. How fast will it be rotated about its vertical axis so that no water will be spilled out?

Ans 109.21 rpm

18. How fast will it be rotated about its vertical axis so as to produce a zero pressure with 0.20m from the center of the tank.

Ans 207.22 rpm

An open cylindrical tank one meter in diameter and 2.5 m high is $\frac{3}{5}$ full of water . if the tank is rotated about its vertical axis , what speed should it have in rpm so that,

19. the water could just reach the rim of the tank.

Ans 119.64 rpm

20. the depth of water at the center is zero

Ans 133.76 rpm

21. there is no water at the bottom with in 20 cm. from the vertical axis

Ans 145.94 rpm

An open cylindrical tank is 1.20 m in diam. And 2.10 m high is $\frac{2}{3}$ full of water.

22. Compute the amount of water in liters that will be spilled out if the vessel is rotated about its vertical axis at a constant speed of 90 rpm

Ans 130 liters

23. At what speed in rpm can the vessel be rotated without spilling any water.

Ans 83.41 rpm

24. At what speed in rpm can the vessel be rotated so that the pressure at the center of the bottom of the tank will not exceed 6.867 kPa.

Ans 83.41 rpm

Resting against the flat top of a closed vessel filled with water is a cube of wood, 15 cm on a side and having a mass of 3 kg. it is fastened to the top by a vertical pin. The vessel is rotated at the rate of 30 rad/sec, about a vertical axis passing through the vessel and at a distance of 1m from one of the vertical faces of the cube.

25. Compute the inward horizontal force acting on the outer side of the cube

Ans 13.39 kN

26. Compute the outward horizontal force acting on the inner side of the cube

Ans 38.60 kN

27. What radial force does the cube exert against the pin?

Ans 25.21 kN

A rectangular Car tank 20 m. long, 4 m wide and 3 m deep is completely open at the top. If its is initially filled to the top.

See figure.

28. How much liquid will be spilled if it is given a horizontal acceleration of 0.3 g in direction of its length.

Ans 180 m³

29. what is the max. force acting on the side opposite to the direction of the acceleration.

Ans 176.58 kN

30. Determine the volume of the remaining water on the tank.

Ans 60 m³

At what angular velocity must a U-tube 0.30 m. in width and filled with water to a depth of 0.30 m be rotated about its axis to cause the water at A to vaporize?

31. ans 919.81 rpm

32. Find the absolute pressure at B in kPa

Ans 104.4 kPa

33. Find the absolute pressure at B in bars

Ans 1.044 bars

A hemispherical bowl having a radius of 1 m is full of water. If the hemispherical bowl is made to rotate uniformly about the vertical axis at the rate of 30 rpm,

34. Determine the volume of water that is spilled out.

Ans 3.14 rad/sec

35. Determine the remaining volume of water in the hemispherical bowl

Ans 0.785

36. Determine the maximum pressure at the bottom of the hemispherical at this instant.

Ans 1.31 m³

An open vessel in the form of a paraboloid having its vertex at the bottom is rotated at a speed of 85 rpm. At this speed the vertex of the paraboloid formed by the water surface was found to be 1 m above the vertex of the containing vessel. When at rest the container contains 254 liters of water when full.

37. Find the height of the open vessel

Ans 0.44m

38. Find the radius of the open vessel

Ans 0.33 m

39. How many liters of water will remain in the vessel when rotated at the above mentioned speed

Ans 177 liters

A closed cylindrical tank 3 m high and 1.5 m in diameter contains 2 m of water with the air space subjected to a pressure of 190 kPa. When the angular velocity is 12 rad/sec.

40. Find the radius of contact of water at the top of the tank measured from the axis of rotation.

Ans 0.63

41. What is the pressure at the bottom of the tank at the center.

Ans 191.67 kPa

42. What is the pressure at the bottom of the tank at the side.

Ans 232.18 kPa

A closed cylindrical tank 1 m in diameter, 3 m high, is full of water. It is rotating about its vertical axis with a speed of 180 rpm. Assuming that the vessel is rigidly constructed.

43. Find the gage pressure, just under the cover at the circumference with a small hole in the cover at the circumference.

Ans 44.34 kPa

44. Find the gage pressure, just under the cover at the center with a small hole in the cover at the circumference.

Ans 0

45. Find the gage pressure, just under the cover at the circumference with a small hole in the cover at the center.

Ans 44.43 kPa

A straight tube 1.2 m long closed at the bottom and filled with water is inclined 30 degrees with the vertical and rotated about a vertical axis through its midpoint at 8.02 rad/sec.

See figure

46. compute the value of y

Ans 0.295 m

47. Compute the value of the pressure at the bottom of the tube.

Ans 10.20 kPa

48. compute the pressure at the midpoint of the curve

Ans. 2.2 kPa

FIGURES

13.

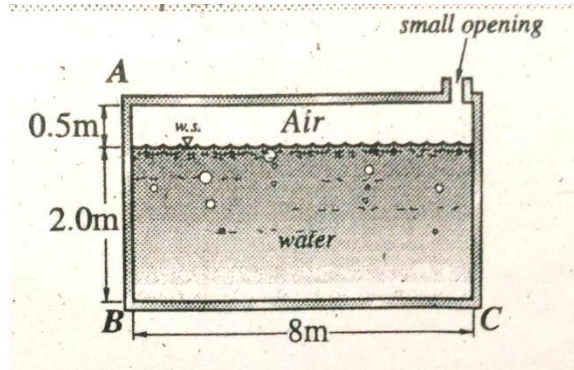

28.

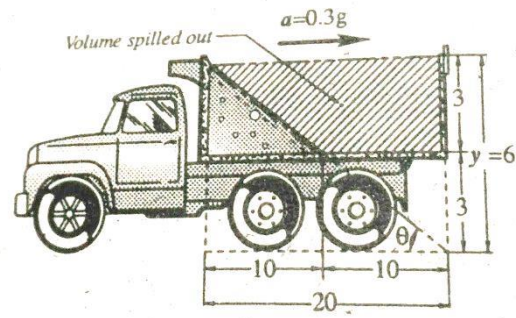

46.

