

NIKHIL MULANE

ELECTRICAL MACHINES-I

ELECTRICAL
MACHINES - 1

ELECTRICAL
MACHINES - 1

DC Machines

The electrical machines deals with the energy transfer either from mechanical to electrical form or from electrical to mechanical form, this process is called electromechanical energy conversion.

An electrical machine which converts mechanical energy into electrical energy is called an electric generator while an electrical machine which converts electrical energy into the mechanical energy is called an electric motor.

A Dc generator is built utilizing the basic principle that emf is induced in a conductor when it cuts magnetic lines of force.

A DC motor works on the basic principle that a current carrying conductor placed in a magnetic field experiences a force.

DC GENERATOR

Working principle: DC generator

All the generators work on the principle of dynamically induced emf. The change in flux associated with the conductor can exist only when there exists a relative motion between the conductor and the flux. The relative motion can be achieved by rotating the conductor w.r.t flux or by rotating flux w.r.t conductor. So, a voltage gets generated in a conductor as long as there exists a relative motion between conductor and the flux. Such an induced emf which is due to physical movement of coil or conductor w.r.t flux or movement of flux w.r.t coil or conductor is called dynamically induced emf. Whenever a conductor cuts magnetic flux, dynamically induced emf is produced in it according to Faraday's laws of Electromagnetic Induction. This emf causes a current to flow if the conductor circuit is closed.

So, a generating action requires the following basic components to exist.

1. The conductor or a coil
2. Flux
3. Relative motion between the conductor and the flux.

In a practical generator, the conductors are rotated to cut the magnetic flux, keeping flux stationary. To have a large voltage as output, a number of conductors are connected together in a specific manner to form a winding. The winding is called armature winding of a dc machine and the part on which this winding is kept is called armature of the dc machine.

The magnetic field is produced by a current carrying winding which is called field winding.

The conductors placed on the armature are rotated with the help of some external device. Such an external device is called a prime mover. The commonly used prime movers are diesel engines, steam engines, steam turbines, water turbines etc.

The purpose of the prime mover is to rotate the electrical conductor as

required by Faraday's laws

The direction of induced emf can be obtained by using Flemings right hand rule. The magnitude of induced emf = $e = BLV \sin\theta = E_m \sin\theta$.

Nature of induced emf

The nature of the induced emf for a conductor rotating in the magnetic field is alternating. As conductor rotates in a magnetic field, the voltage component at various positions is different.

Hence the basic nature of induced emf in the armature winding in case of dc generator is alternating. To get dc output which is unidirectional, it is necessary to rectify the alternating induced emf. A device which is used in dc generator to convert alternating induced emf to unidirectional dc emf is called commutator.

Construction of DC machines :

A D. C. machine consists of two main parts

1. Stationary part: It is designed mainly for producing a magnetic flux.
2. Rotating part: It is called the armature, where mechanical energy is converted into electrical (electrical generate) or conversely electrical energy into mechanical (electric into)

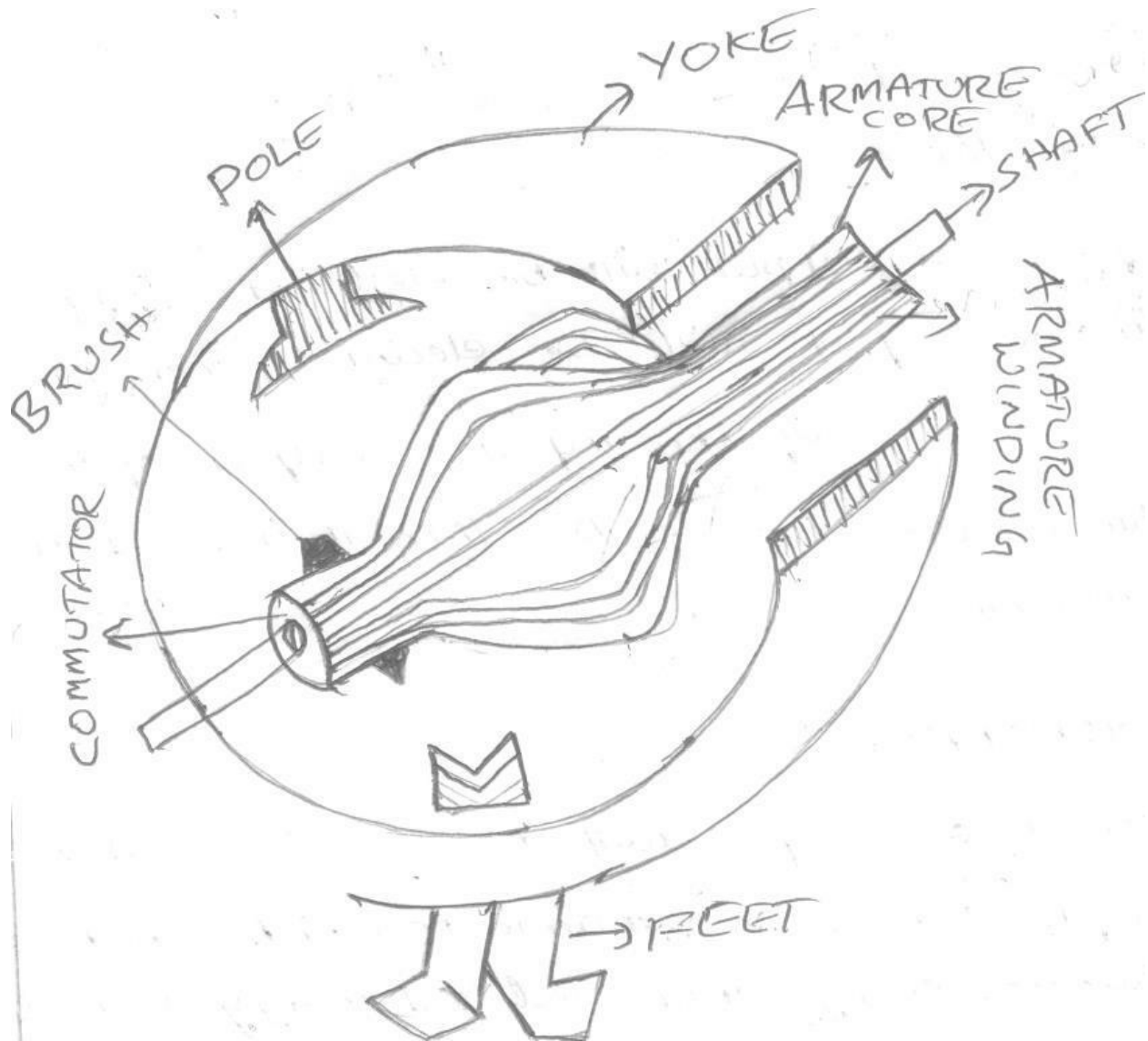

Parts of a Dc Generator :

- 1) Yoke
- 2) Magnetic Poles
 - a) Pole core
 - b) Pole Shoe
- 3) Field Winding
- 4) Armature Core
- 5) Armature winding
- 6) Commutator
- 7) Brushes and Bearings

The stationary parts and rotating parts are separated from each other by an air

gap. The stationary part of a D. C. machine consists of main poles, designed to create the magnetic flux, commutating poles interposed between the main poles and designed to ensure spark less operation of the brushes at the commutator and a frame / yoke. The armature is a cylindrical body rotating in the space between the poles and comprising a slotted armature core, a winding inserted in the armature core slots, a commutator and brush

Yoke:

1. It serves the purpose of outermost cover of the dc machine so that the insulating materials get protected from harmful atmospheric elements like moisture, dust and various gases like SO_2 , acidic fumes etc.
2. It provides mechanical support to the poles.
3. It forms a part of the magnetic circuit. It provides a path of low reluctance for magnetic flux.

Choice of material : To provide low reluctance path, it must be made up of some magnetic material. It is prepared by using cast iron because it is the cheapest. For large machines rolled steel or cast steel, is used which provides high permeability i.e., low reluctance and gives good mechanical strength.

Poles: Each pole is divided into two parts a) pole core b) pole shoe

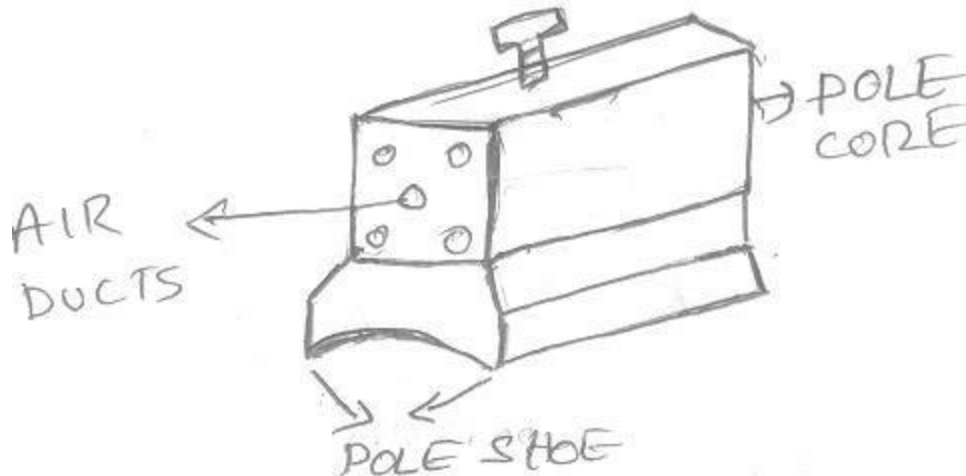

Functions: 1.

Pole core basically carries a field winding which is necessary to produce the flux.

2. It directs the flux produced through air gap to armature core to the next pole.
3. Pole shoe enlarges the area of armature core to come across the flux, which

is necessary to produce larger induced emf.

To achieve this, pole core has been given a particular shape.

Choice of material : It is made up of magnetic material like cast iron or cast steel. As it requires a definite shape and size, laminated construction is used. The laminations of required size and shape are stamped together to get a pole which is then bolted to yoke.

Armature: It is further divided into two parts namely,

(1) Armature core (2) Armature winding.

Armature core is cylindrical in shape mounted on the shaft. It consists of slots on its

periphery and the air ducts to permit the air flow through armature which serves

cooling purpose.

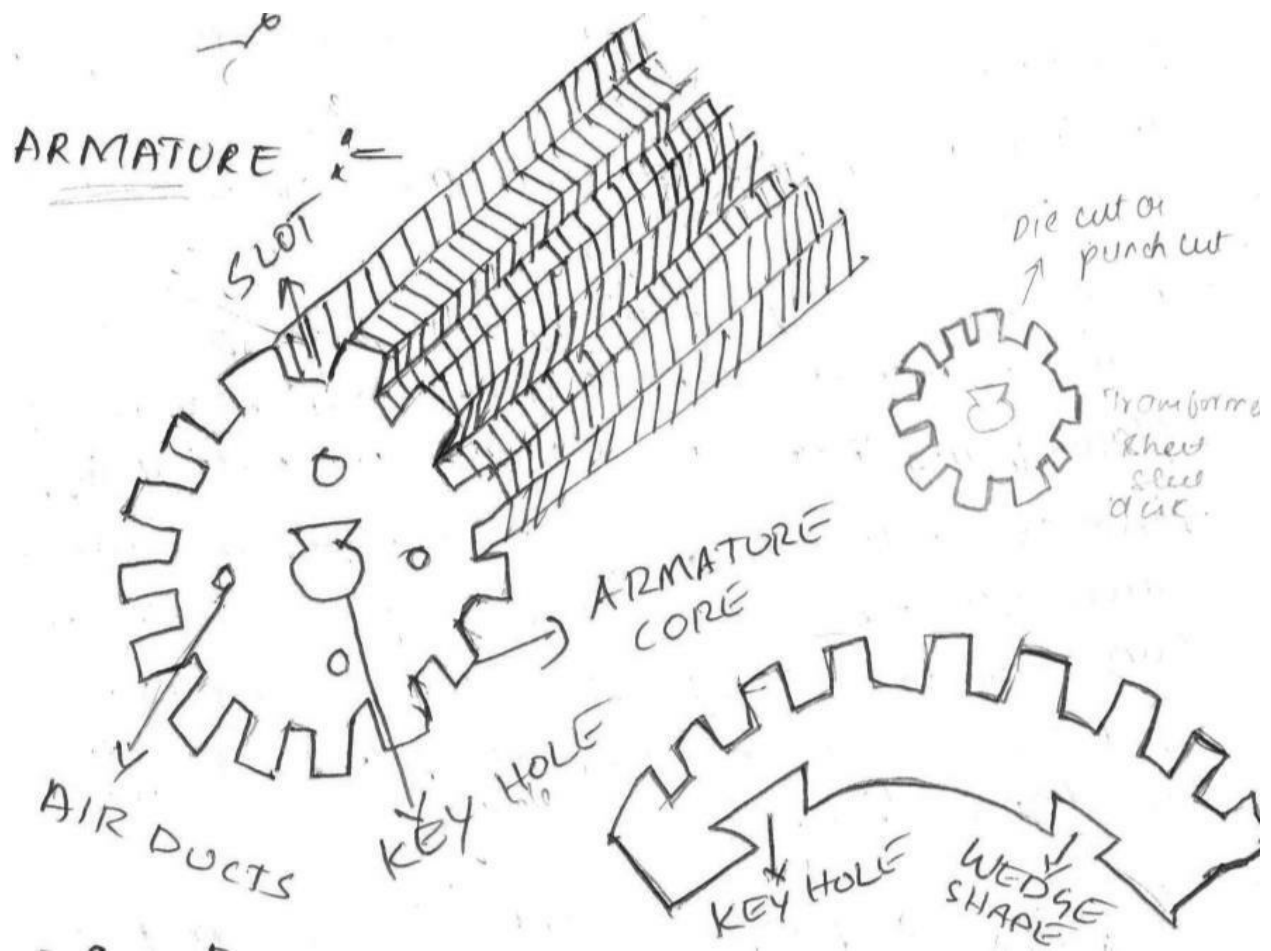

Functions:

1. Armature core provides house for armature winding i.e., armature conductors.
2. To provide a path of low reluctance path to the flux it is made up of magnetic material like cast iron or cast steel.

Choice of material : As it has to provide a low reluctance path to the flux, it is made up of magnetic material like cast iron or cast steel.

It is made up of laminated construction to keep eddy current loss as low as possible. A single circular lamination used for the construction of the armature core is shown below.

2. Armature winding: Armature winding is nothing but the inter connection of the armature conductors, placed in the slots provided on the armature core. When the armature is rotated, in case of generator magnetic flux gets cut by armature conductors and emf gets induced in them.

Function:

1. Generation of emf takes place in the armature winding in case of generators.
2. To carry the current supplied in case of dc motors.
3. To do the useful work in the external circuit.

Choice of material : As armature winding carries entire current which depends on external load, it has to be made up of conducting material, which is copper.

Field winding: The field winding is wound on the pole core with a definite direction.

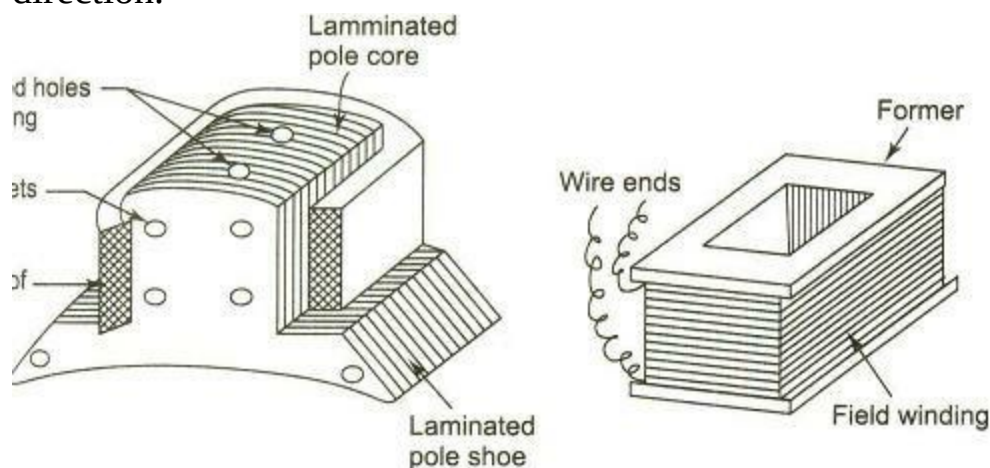

Functions: To carry current due to which pole core on which the winding is placed behaves as an electromagnet, producing necessary flux. As it helps in producing the magnetic field i.e. exciting the pole as electromagnet it is called '**Field winding**' or '**Exciting winding**'.

Choice of material : As it has to carry current it should be made up of some conducting material like the aluminum or copper. But field coils should take any type of shape should bend easily, so copper is the proper choice.

Field winding is divided into various coils called as field coils. These are connected in series with each other and wound in such a direction around pole cores such that alternate N and S poles are formed.

Commutator: The rectification in case of dc generator is done by device called as commutator.

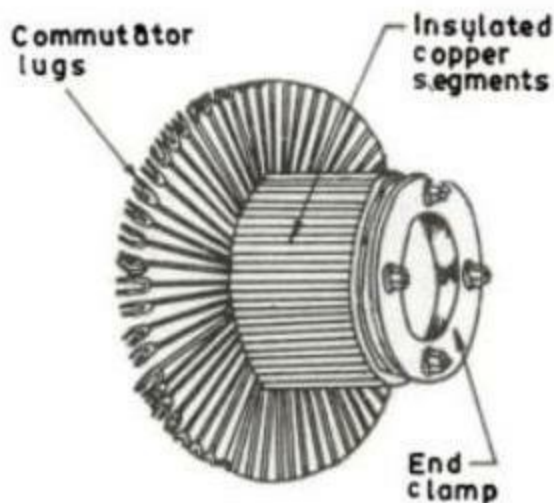

Functions: 1. To facilitate the collection of current from the armature conductors.
2. To convert internally developed alternating emf to in directional (dc) emf
3. To produce unidirectional torque in case of motor.

Choice of material : As it collects current from armature, it is also made up of copper segments. It is cylindrical in shape and is made up of wedge shaped segments which are insulated from each other by thin layer of mica.

Brushes and brush gear : Brushes are stationary and rest on the surface of the commutator. Brushes are rectangular in shape. They are housed in brush holders, which are usually of box type. The brushes are made to press on the

commutator surface by means of a spring, whose tension can be adjusted with the help of lever. A flexible copper conductor called pigtail is used to connect the brush to the external circuit.

Lecture Notes

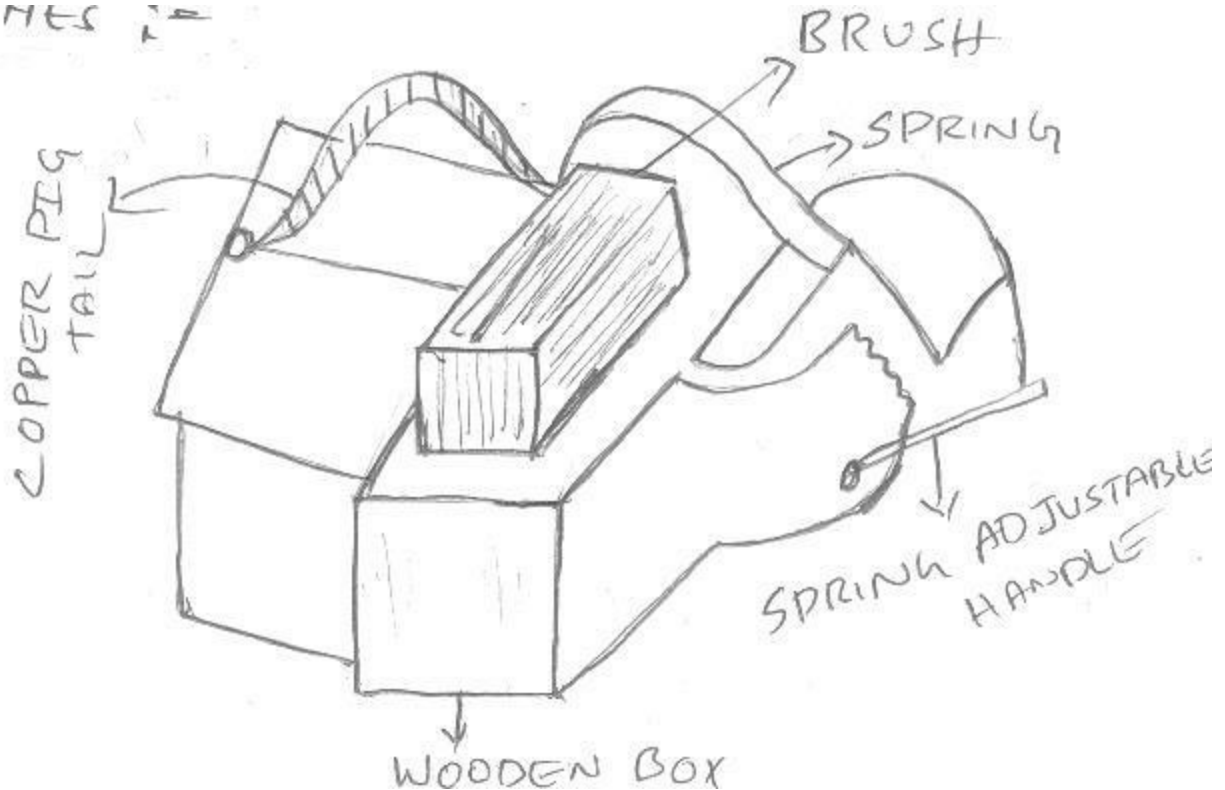

Md.Asif Page 7

Functions: To collect current from commutator and make it available to the stationary external circuit.

Choice of material : Brushes are normally made up of soft material like carbon.

Bearings: Ball-bearings are usually used as they are more reliable. For heavy duty machines, roller bearings are preferred.

Working of DC generator

The generator is provided with a magnetic field by sending dc current through the field coils mounted on laminated iron poles and through armature winding.

A short air gap separates the surface of the rotating armature from the stationary pole surface. The magnetic flux coming out of one or more worth

poles crossing the air gap, passes through the armature near the gap into one or more adjacent south poles.

The direct current leaves the generator at the positive brush, passes through the circuit and returns to the negative brush.

The terminal voltage of a dc generator may be increased by increasing the current in the field coil and may be reduced by decreasing the current.

Generators are generally run at practically constant speed by their prime movers.

Types of generators: Generators are usually classified according to the way in which their fields are excited. Generators may be divided into

a) **Separately excited generators:** These are generators whose field magnets are

energized from an independent external source of dc current.

I_a IL V



R_a E_g Load

Field winding

b) **Self-excited generators:** These are generators whose field magnets are energized by the current produced by the generators themselves.

Due to residual magnetism, there is always present some flux in the poles when the

armature is rotated, some emf and hence some induced current is produced which is

partly or fully passed through the field coils thereby strengthening the residual pole

flux.

The self-excited generators are again divided into three types according to the manner in which their field coils or winding are connected to the armature.

1) Series Generator

2) Shunt Generator

3) Compound Generator

i. Long Shunt Compound Generator ii. Short Shunt Compound Generator

Series Generator: It is a generator where the field winding is connected in series with the armature

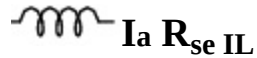

$R_a E_g$ Load

Shunt Generator: It is a generator where the field winding is connected in series with the armature

$I_a IL$

R_{Sh}

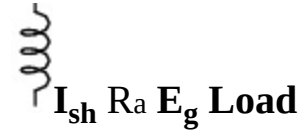

Compound Generator: It is generator which has both Series and Shunt Windings. Compound generators are of two types.

a) Long Shunt Compound Generator

b) Short Shunt Compound Generator

Long Shunt Compound Generator:

R_{Sh}

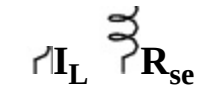

I_a Load

$R_a E_g$

Short Shunt Compound Generator:

I_{se}

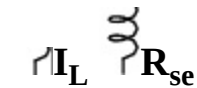

I_a Load

R_{Sh}



Types of armature winding

Armature conductors are connected in a specific manner called as armature winding and according to the way of connecting the conductors, armature

winding is divided into two types.

Lap winding : In this case, if connection is started from conductor in slot 1 then the connections overlap each other as winding proceeds, till starting point is reached again.

There is overlapping of coils while proceeding. Due to such connection, the total number of conductors get divided into 'P' number of parallel paths, where

P = number of poles in the machine.

Large number of parallel paths indicate high current capacity of machine hence lap winding is pertained for high current rating generators.

Wave winding : In this type, winding always travels ahead avoiding overlapping. It travels like a progressive wave hence called wave winding. Both coils starting from slot 1 and slot 2 are progressing in wave fashion. Due to this type of connection, the total number of conductors get divided into two number of parallel paths always, irrespective of number of poles of machine. As number of parallel paths are less, it is preferable for low current, high voltage capacity generators.

Sl. **Lap winding**_{No.}

Wave winding

1. Number of parallel paths (A) = poles (P) Number of parallel paths (A) = 2 (always)

2.

Number of brush sets required is equal to number of poles

Number of brush sets required is always equal to two

3.

Preferable for high current, low voltage capacity generators

Preferable for high current, low current capacity generators

4.

Normally used for generators of capacity more than 500 A

Preferred for generator of capacity less than 500 A.

EMF equation of a generator

Let P = number of poles

ϕ = flux/pole in webers

Z = total number of armature conductors.

= number of slots \times number of conductors/slot

N = armature rotation in revolutions (speed for armature) per minute (rpm) A

= No. of parallel paths into which the 'z' no. of conductors are divided. E = emf induced in any parallel path

E_g = emf generated in any one parallel path in the armature.

Average emf generated/conductor = $d\phi/dt$ volt

Flux current/conductor in one revolution

$d\phi = \phi \times p$

In one revolution, the conductor will cut total flux produced by all poles = $\phi \times p$

No. of revolutions/second = $N/60$

Therefore, Time for one revolution, $dt = 60/N$ second

According to Faraday's laws of Electromagnetic Induction, emf generated/conductor

= $d\phi/dt = \phi \times p \times N / 60$ volts

This is emf induced in one conductor.

For a simplex wave-wound generator

No. of parallel paths = 2

No. of conductors in (series) in one path = $Z/2$

EMF generated/path = $\phi PN/60 \times Z/2 = \phi ZPN/120$ volt

For a simple lap-wound generator

Number of parallel paths = P

Number of conductors in one path = Z/P EMF generated/path = $\phi PN/60$

$(Z/P) = \phi ZN/60$ A = 2 for simplex – wave winding

A = P for simplex lap-winding

Characteristics of dc generators

The dc generators have the following characteristics in general 1.

Magnetization characteristics

2. Load characteristics

Magnetization characteristics

It is also known as no-load saturation characteristics or open-circuit characteristics (OCC)

This characteristics is the graph of the no-load generated emf E_0 and the field current I_f , at a given speed.

As it is plotted without load with open output terminals it is also called no load characteristics or open circuit characteristics.

No-load curve for self-excited generator

The O.C.C. or no-load curves for self-excited generators whether shunt or seriesconnected are obtained in a same way.

The field winding of the generator (whether shunt or series wound) is disconnected from the machine and connected to an external source of direct current. The field or exciting current I_f is varied the statically its value is read on the armature A.

The machine is driven at constant speed by the prime moves and the generated emf on on-load is measured by the voltmeter connected across the armature. I_f is increased by suitable steps starting from zero and the corresponding values of E_0 are measured on plotting the relation between I_f and E_0 a curve of the forms shown in obtained.

Due to residual magnetism in the poles some emf is generated even when $I_f = 0$ hence the curve starts from point A.

E_0 vs I_f magnetization characteristics.

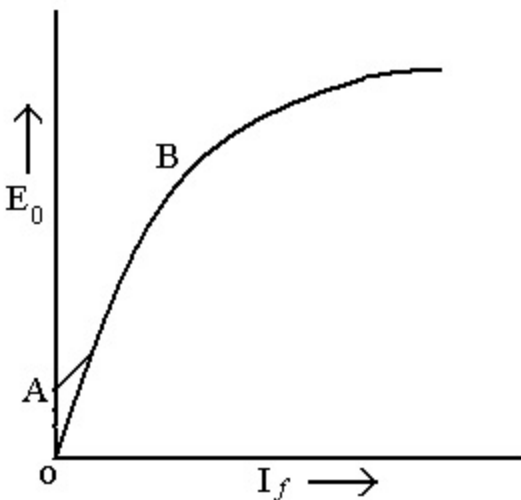

Critical resistance for shunt generator Critical resistance is that value of resistance in the field circuit, which enables the machine just to start building

up.

Now, connect the field windings back to the armature and run the machine as a shunt generator.

Due to residual magnetism, some initial emf and hence current, would be generated. This current while passing through the field coils will strengthen the magnetisation at the poles.

This will increase the pole flux which will further increases the generated emf. Increased emf means more current which further increases the flux and so on. The value of the resistance represented by the tangent to the curve is known as critical resistance R_c for a given speed.

Thus induced emf increases directly as I_f increases. But after certain time, If core gets saturated flux ϕ also remains constant through I_f increases.

Induced emf also varies with speed, we will get a family of parallel characteristics for lower speeds, generated voltage are less so characteristics for lower speeds are below the characteristics for higher

Losses in a Dc Generator:

Variable losses : The armature current varies with load . The copper losses that occur in the armature also vary w.r.t to load A_r C_u loss = $I_a^2 R_a$

Magnetic losses :

Hysteresis : The property of a magnetic material to retain a part of the magnetism achieved by it, one removal of the driving force is called hysteresis.

The power required to overcome this hysteresis effect is called hysteresis loss. It is denoted by W_h .

$$W_h \sim f$$

$$\sim B_{m1.6}$$

$$W_h = \eta B_{m1.6} f V$$

Where , η =Steinmetz Constant

B=Flux Density

F=Frequency

V=Volume Of the core

Eddy current losses : When the iron part (rotor) rotates in the stationary field, there is an induced emf in the iron part also apart from the emf induced in the copper windings. This emf is called eddy emf. The iron part provides a closed path for the eddy emf to circulate a current. This current is called eddy current. The power required to be generated by the machine to overcome the effect of eddy current is called eddy current loss. It is denoted by w_e .

$$W_e \sim B_m^2 f^2 t^2.$$

Mechanical losses :

1. Friction losses : The rotation of the armature inside the bearings causes friction to be developed. In order to overcome this, the prime mover has to supply more power.
2. Windage losses : An extra mounting on the shaft of the armature such as fan to provide air for cooling purposes causes an extra burden on the prime mover. The extra power required to drive the fan is termed as windage loss. (constant)

Stray losses :

The magnetic and mechanical losses are collectively known as stray losses. These are also known as rotational losses

Constant and standing losses: The field current loss is constant. Hence, stray losses

and shunt current losses are constant these losses are together known as **standing** or

constant losses W_c .

Hence, for shunt and compound generators.

Total loss = armature cu loss + w_c

$$= I_a^2 R_a + w_c$$

$$(I + I^{gh})^2 R_a + W_c$$

An current loss, $I_a^2 R_a$ is known as variable loss because it varies with the current.

Total loss = variable loss + constant loss w_c .

Efficiency of a DC Generator:

Shunt Generator:

Output Power = Input Power - Losses

Input Power = VI

Losses = Armature Copper Losses ($I_a^2 R_a$) + Constant Losses (W_c)

Efficiency = Output / Input = Input - Losses / Input

$$\eta = \frac{VI - (I_a^2 R_a + W_c)}{VI}$$

In a Shunt Generator $I = I_a + I_{sh}$

Here I_{sh} is negligible

So $I = I_a$

So, $\eta = \frac{VI_a - (I_a^2 R_a + W_c)}{VI_a}$

$$= 1 - \frac{(I_a R_a / V) + W_c / VI_a}{1} \text{-----(1)}$$

Condition for maximum efficiency:

For maximum efficiency differentiate equation (1) and equate to zero

$$\frac{d(\eta)}{dI_a} = \frac{d(1 - (I_a R_a / V) - W_c / VI_a)}{dI_a} = 0$$

$$= 0 - R_a / V + W_c / VI_a^2 = 0$$

$$R_a / V = W_c / VI_a^2$$

$$W_c = I_a^2 R_a$$

1) Mechanical efficiency =

$\frac{E_g I_a}{m \tau}$ total watts generated in armature \approx

$\frac{m \tau}{A}$ A mechanical power supplied

$$E_g I_a$$

output of during emf

2. Electrical efficiency

$$\approx \frac{V I_a - W_c}{V I_a} \text{ } C \tau \text{ watts available in local circuit} = E_g I_a$$

3. Overall efficiency

$$C \tau \text{ watts available in local circuit} = \approx \tau \approx G \approx \approx \tau$$

c A mechanical power supplied^{c m e}

DC Motor

A dc motor is similar in construction to a dc generator. As a matter of fact a dc generator will run as a motor when its field & armature windings are connected to a source of direct current.

The basic construction is same whether it is generator or a motor.

Working principle : The principle of operation of a dc motor can be stated as when a current carrying conductor is placed in a magnetic field; it experiences a mechanical force. In a practical dc motor, the field winding produces the required magnetic held while armature conductor play the role of current carrying conductor and hence the armature conductors experience a force.

As conductors are placed in the slots which are on the periphery, the individual force experienced by the conductive acts as a twisting or turning force on the armature which is called a torque.

The torque is the product of force and the radius at which this force acts, so overall armature experiences a torque and starts rotating.

Consider a single conductor placed in a magnetic field , the magnetic field is produced by a permanent magnet but in practical dc motor it is produced by the field winding when it carries a current.

Now this conductor is excited by a separate supply so that it carries a current in a particular direction.

Consider that it carries a current away from an current. Any current carrying conductor produces its own magnetic field around it, hence this conductor also produces its own flux, around. The direction of this flux can be determined by right hand thumb rule. For direction of current considered the direction of flux around a conductor is clock-wise. Now, there are two fluxes present

1. Flux produced by permanent magnet called main flux

2. Flux produced by the current carrying conductor

From the figure shown below, it is clear that on one side of the conductor, both the fluxes are in the same direction in this case, on the left of the conductor there gathering of the flux lines as two fluxes help each other. As to against this, on the right of the conductor, the two fluxes are in opposite direction and hence try to cancel each other. Due to this, the density of the flux lines in this area gets weakened.

So on the left, there exists high flux density area while on the right of the conductor then exists low flux density area as shown.

The flux distribution around the conductor acts like a stretched ribbed band under tension. This exerts a mechanical force on the conductor which acts from high flux density area towards low flux density area, i.e. from left to right from the case considered as shown above.

In the practical dc motor, the permanent magnet is replaced by the field winding which produces the required flux winding which produces the required flux called main flux and all the armature conductors, would on the periphery of the armature gram, get subjected to the mechanical force.

Due to this, overall armature experiences a twisting force called torque and armature of the motor starts rotating.

Direction of rotation of motor

The magnitude of the force experienced by the conductor in a motor is given by $F = BIL$ newtons.

The direction of the main field can be reversed by changing the direction of current passing through the field winding, which is possible by interchanging the polarities of supply which is given to the field winding.

The direction of current through armature can be reversed by changing supply polarities of dc supplying current to the armature.

If directions of both the currents are changed then the direction of rotation of the motor remains undamaged.

In a dc motor both the field and armature are connected to a source of direct current. The current through the armature winding establishes its own magnetic

flux the interaction both the main field and the armature current produces the torque, there by sensing the motor to rotate, once the motor starts rotating, already existing magnetic flux there will be an induced emf in the armature conductors due to generator action. This emf acts in a direction opposite to supplied voltage. Therefore it is called Back emf.

Significance of Back emf

In the generating action, when a conductor cuts the lines of flux, emf gets induced in the conductor in a motor, after a motoring action, armature starts rotating and armature conductors cut the main flux.

After a motoring action, there exists a generating action there is induced emf in the rotating armature conductors according to Faraday's law of electromagnetic induction. This induced emf in the armature always acts in the opposite direction of the supply voltage. This is according to Lenz's law which states that the direction of the induced emf is always so as to oppose the cause producing it.

In a dc motor, electrical input i.e., the supply voltage is the cause and hence this induced emf opposes the supply voltage.

The emf tries to set up a current throughout the armature which is in the opposite direction to that which supply voltage is forcing through the conductor so, as this emf always opposes the supply voltage, it is called back emf and denoted as E_b .

Through it is denoted as E_b , basically it gets generated by the generating action

↳ **ZNP** which we have seen earlier So, $E_b \uparrow 60A$

Voltage equation of a Motor

The voltage v applied across the motor armature has to (1) overcome the back emf E_b and

(1) supply the armature ohmic drop $I_a R_a$

$$v = E_b + I_a R_a$$

This is known as voltage equation of a motor

Multiplying both sides by I_a , we get

$$v I_a = E_b I_a + I_a^2 R_a$$

$v I_a$ = electrical input to the armature

$E_b I_a$ = electrical equivalent of mechanical Power developed in the armature

$I_a^2 R_a$ = un loss in the armature

Hence, out of the armature input, some is wasted in $I_a^2 R_a$ loss and the rest is converted into mechanical power within the armature.

Motor efficiency is given by the ratio of power developed by the armature to its input i.e. $E_b I_a / v I_a = E_b / v$.

Higher the value of E_b as compared to v , higher the motor efficiency.

Conduction for maximum powers

The gross mechanical developed by a motor = $p_m = v I_a - I_a^2 R_a$

$$dP_m = v I_a - 2 I_a R_a = v/2 dI_a$$

As $v = E_b + I_a R_a$ and $I_a R_a = v/2$ $E_b = v/2$

Thus gross mechanical power developed by a motor is maximum when back emf is equal to half the applied voltage. This condition's how ever at realized in practice, because in that case current will be much beyond the normal current of the motor.

More over, half the input would be wasted in the form of heat and taking other losses into consideration the motor efficiency will be well below 50 %.

1. A 220v – dc machine has an armature resistance of 0.5 Ω . If the full load armature current is 20A, find the induced emf when the machine acts (1) generator (2) motor.

The dc motor is assumed to be shunt connected in cash case, shunt current is considered negligible because its value is not given.

(a) As generator $E_g = v + I_a R_a = 220 + 0.5 \times 20 = 230$ v (b) As motor $E_b = v - I_a R_a = 220 - 0.5 \times 20 = 210$ v

2. A 440 v, shunt motor has armature resistance of 0.8 Ω and field resistance of 200 Ω . Determine the back emf when giving an output at 7.46 kw at 85% efficiency.

7.46 x 10

3

Motor input power = 0.85 w 7460 Motor input current = 0.85x 440 $\hat{=}$ 19.95 A

3. A 25kw, 250 v dc such generator has armature and field resistance of 0.06 Ω and 100 Ω respectively. Determine the total armature power developed when working (1) as generator delivering 25 kw output and (2) as a motor taking 25 kw input.

Voltage equation of dc motor

For a generator, generated emf has to supply armature resistance drop and remaining part is available across the load as a terminal voltage. But in case of dc motor, supply voltage v has to overcome back emf E_b which is opposing v and also various drops are armature resistance drop $I_a R_a$, brush drop etc. In fact the electrical work done in overcoming the back emf gets converted into the mechanical energy, developed in the armature.

Hence, the voltage equation of a dc motor is $V = E_b + I_a R_a + \text{brush drops}$
Or $v = E_b + I_a R_a$ neglecting brush drops

The back emf is always less than supply voltage ($E_b < v$) but R_a is very small hence under normal running conditions, the difference between back emf and supply voltage is very small. The net voltage across the armature is the difference between the supply voltage and back emf which decides the armature current. Hence from the voltage equation we can write $I_a = (v - E_b) / R_a$.

1. A 220 v dc motor has an armature resistance of 0.75 Ω it is drawing an armature current of 30 A, during a certain load, calculate the induced emf in the motor under this condition.

$$V = 200 \text{ v}, I_a = 30\text{A}, R_a = 0.75\Omega$$

$$\text{For a motor, } v = E_b + I_a R_a$$

$$E_b = 197.5 \text{ v}$$

This is the induced emf called back emf in a motor.

2. A 4-pole dc motor has lap connected armature winding. The number of armature conductors is 250. When connected to 230 v dc supply it draws an armature current $I_a = 40$ A calculate the back emf and the speed with which motor is running. Assume armature resistance is 0.6Ω

$P = 4$ A = P = 4 as lap connected

$\phi = 30$ m wb = 30 Ho^{-3} V = 230V, $z = 250$ $I_a = 40$ A From voltage equation

$$V = E_b + I_a R_a$$

$$230 = E_b + 40 \times 0.6$$

$$E_b = \phi Pnz / 60A$$

$$206 = (30 \times 10^{-3} \times 4 \times N \times 250) / (60 \times 4)$$

$$N = 1648 \text{ rpm.}$$

Torque: The turning or twisting movement of a body is called Torque. (Or) It is defined as the product of force and perpendicular distance $\check{T} = F \times R$ In case of DC motor torque is produced by the armature and shaft called as armature torque (T_a) and shaft torque (T_{sh}).

Let, N be the speed of the armature in RPM R be the radius of the armature

Power = Work Done / Time

Work Done = Force X Distance

The distance travelled in rotating the armature for one time = $2\pi R$

If N rotations are made in 60 sec

Then time taken for one rotation is = $60/N$

So, Power = $(F \times 2\pi R) / (60/N)$

$$= (F \times R)(2\pi N) / 60 \quad P = \check{T}\omega$$

Here $P = E_b I_a$

But $E_b = \phi ZNP / 60A$

$$(\phi ZNP / 60A) I_a = \check{T}\omega$$

$$= \check{T}_a (2\pi N) / 60$$

$$\check{T}_a = 0.159 \phi Z I_a P / A$$

Similarly, Shaft torque $T_{sh} = \text{output} / \omega$

$$T_{sh} = \text{output} / ((2\pi N) / 60) \quad T_{sh} = 9.55 (\text{output}) / N$$

DC Motor characteristics

1. Torque and armature current (T_a/I_a characteristics) It is also known as electrical characteristics.

2. Speed and armature current i.e., (N/T_a characteristics). It is also known as mechanical characteristics.

While discussing motor characteristics, the following two relations should always be kept in mind.

$$T_a \propto \phi I_a \text{ \& } N \propto E_b / \phi .$$

Characteristics of series motors 1. T_a/I_a Characteristics. For series motor $\phi \propto I_a$ $T_a \propto \phi I_a$

$\propto I_a^2$ Thus, torque in case of series motor is proportional to the square of the armature current

T_a

T_{sh}

I_a

As the load increases, armature current increases and torque produced increases proportional to the square of the armature current upto a certain limit.

Hence T_a/I_a curve is a parabola.

After saturation, ϕ is almost independent I_a , hence $T_a \propto I_a$ only.

So, the characteristic becomes a straight line.

The shaft torque T_{sh} is less than the armature torque due to stray losses. It is shown dotted in the figure.

On heavy loads, a series motor events a torque proportional to the square of armature current.

Hence, where large starting torque is required for accelerating heavy masses quickly as in hasps and electric trains etc. series motors are used.

2. N/I_a characteristic $N \propto (E_b / \phi) \propto [V - I_a (R_a + R_{se}) / I_a]$

The values R_a and R_{se} are so small as $\phi \propto I_a$ in case of series motor that the effect of change in I_a on speed avoid the effect of change in $V - I_a R_a - I_a R_{se}$

on speed change in E_b for various load currents is small and hence may be neglected.

N

I_a

With increased I_a , E_b also increases Hence, speed varies inversely as armature current. When load is heavy, I_a is large. Hence speed is low (this increases E_b and allows more armature current to flow). But when load current and hence I_a falls to a small value speed becomes dangerously high.

Hence, a series motor should never be started without some mechanical load on it otherwise it may develop excessive speed and get damaged due to centrifugal loss so produced. Series motor is a variable speed motor.

N/ I_a characteristic:

$$T \approx I_a^2$$

$$N \approx 1/I_a$$

$$I_a \approx T_a$$

$$1/N \approx T_a$$

$$T \approx 1/N^2$$

Thus for small T, speed is large while for large T speed is small. N

T_a

As I_a increases, torque increases and speed decreases so as torque increases, speed decreases is the nature of this curve, which is similar to speed current curve.

Characteristics of shunt Motors

1. T_a/I_a characteristics:

$$T \approx k I_a$$

For a constant value of R_{sh} and supply voltage, V , I_{sh} is also constant and hence flux is also constant.

$$T \approx I_a$$

The equation represents a straight line passing through the origin. Torque increases linearly with armature current.

It is seen earlier that armature current is decided by the load. So as load increases, armature current increases, increasing the torque developed linearly.

$$T = T_a - T_{sh}$$

I_a

Now, if shaft torque is plotted against armature current, it is known that shaft torque is less than the armature torque and the difference between the two is load torque T_L .

Since a heavy starting load will need a heavy starting current, shunt motor should never be started on large load.

2. N/I_a characteristic:

If k is assumed constant, $N \approx E_b$.

As E_b is also practically constant, speed is constant
But strictly speaking, both E_b & ϕ decreases with increasing load. However, E_b decreases slightly more than ϕ so that on the whole, there is some decrease in speed.

N
Ia

The drop varies from 5 to 15% of full-load speed, being dependent on saturation, armature reaction and brush position. Hence, the actual speed curve is slightly dropping as shown by the dotted line.

But, for all practical purposes, shunt motor is taken as a constant speed motor. Because, there is no appreciable change in the speed of a shunt motor from no-load to full-load, it may be connected to loads which are totally and suddenly thrown off without any term of excessive speed resulting.

Since a heavy starting load will need a heavy starting current, shunt motor should never be started on heavy load.

Due to the constancy of their speed, shunt motors are suitable for driving shafting, machine tools, lathes, wood-working machines and for all other purposes where an approximately constant speed is required.

3. N/Ta characteristics

These can be deduced from the above two characteristics. This graph is similar to speed-armature current characteristics as torque is proportional to the armature current. This curve shows that the speed almost remains constant through torque changes from no load to full load conditions.

N
Ta

Compound Motors :

Compound motor characteristics basically depend on the fact whether the motor is cumulatively compound or differential compound. All the characteristics of the compound motor are the combination of the shunt and series characteristics.

Cummulative – compound motors

These are capable of developing large amount of torque at low speeds just like a series motor. However it is not having a disadvantage of series motor even at light or no load.

Due to shunt windings, speed will not become excessively high but due to series windings, it will be able to take heavy loads.

Differential compound: Here the two fluxes oppose each other, the resultant flux decreases as load increases, thus the machine runs at a higher speed with increase in the load. This property is dangerous as

The following results were obtained from a static torque tests on a series motor: Current (A) : 20 30 40 50

128.8 230.5 349.8 469.2

Deduce the speed/torque curve for the machine when supplied at a constant voltage of 460 v.

Resistance of armature and field winding is 0.5 Ω . Ignore iron and friction losses. When input current is 20A, we have

Motor input = $460 \times 20 = 9,200 \text{ W}$

Field and armature cu loss = $20^2 \times 0.5 = 200 \text{ W}$ Ignoring iron and friction losses, output = $9,200 - 200$

= 9000 w

$T_{sh} \times 2 \sqrt{N} = \text{output in watts}$

$128.8 \times 2 \sqrt{N} = 9,000$

$N = 9000 / (2 \sqrt{128.8}) = 11.12 \text{ rps} = 66.7 \text{ rpm}$

Current (A)	20	30	40	50	Input (W)	9200	13800	18400	23000	$I^2 R$ loss(w)	200	450	800	1250	Output (w)	9000	13350	17600	21850	Speed (rpm)	667	551	480	445	Torque (N-m)	128.8	230.5	349.8	469.2
-------------	----	----	----	----	-----------	------	-------	-------	-------	-----------------	-----	-----	-----	------	------------	------	-------	-------	-------	-------------	-----	-----	-----	-----	--------------	-------	-------	-------	-------

On all road, the motor may try to run with dangerously high speed. So, differential compound motor is generally not used in practice.

The exact shape of these characteristics depend on the relative contribution of series and shunt field windings. If the shunt field winding is more dominant, then the characteristics take the shape of the shunt motor characteristics.

While, if the series field winding is more dominant than the characteristic, it takes the shape of series characteristic.

Type of Motor Shunt

Series Characteristics

Approximately constant speed. Adjustable speed medium starting torque (up to 1.5 F. L. torque)

Variable speed adjustable varying speed high starting torque

Cumulative compound Variable speed adjustable varying speed high starting torque

Applications

For during constant speed some centrifugal pumps machine tools blows and fans reciprocating pumps

For traction work i.e. electric locomotives repaid transit system trolley cars etc. Cranes and hoists conveyors.

For intermittent high torque load for shears and punches elevators conveyors

2. A 500 V DC shunt motor takes a current of 5 A on no-load. The resistance of the armature and field circuits are 0.22 Ω and 250 Ω respectively. Find (a) the efficiency when loaded and taking a current of 100 A.

b) The percentage change of speed state precisely the assumptions made.

No-load condition

$$I_{sh} = 500/250 = 2A$$

$$I_{a0} = 5 - 2 = 3A$$

$$E_{b0} = 500 - (3 \times 0.22) = 499.34 \text{ V}$$

$$\text{Ar. cu. loss} = 3^2 \times 0.22 = 2110 \text{ W}$$

$$\text{Total losses} = 2110 + 2498 = 4608$$

$$\text{Motor input} = 500 \times 100 = 50000 \text{ W}$$

$$\text{Motor output} = 50000 - 4608$$

$$= 45392 \text{ W}$$

$$\eta = 45392/50000 = 0.9078 \approx 90.8\%$$

$$N/N_0 = E_b/E_{b0} = 478.44/499.34 \text{ or}$$

$$(N-N_0)/N_0 = -20.9/499.34 = -0.0418 \text{ or } -4.18\%$$

4. The armature winding of a 4-pole, 250-v, dc shunt motor is lap connected there are 120 slots, each slot containing 8 conductors. The flux per pole is 20 m wb and the current taken by the motor is 25 A. The resistance of armature and field circuit are 0.1 and $125\ \Omega$ respectively.

5. If the rotational losses amount to 810w, find the developed torque and useful torque of the machine.

$$I_a = 25 - 2 = 23\text{ A}$$

$$E_b = 250 - (23 \times 0.1) = 247.7\text{ v}$$

$$E_b = \frac{f \phi Z}{60} \left(\frac{p}{A} \right) \quad 247.7 = \frac{(2 \times 10^{-3} \times 960 \times N)}{60} = (4/4)$$

$$N = 9.55 (E_b I_a) / P \quad N = 773\text{ rpm} = 9.55 \times (247.7 \times 23) / 773 = 70.4\text{ N-m}$$

$$b) \text{ Armature loss} = 23^2 \times 0.1 = 53\text{ w}$$

$$\text{shunt cu loss} = 250 \times 2 = 500\text{ w} \quad \text{Rotational losses} = 810\text{ w}$$

$$\text{Total motor losses} = 1363\text{ w}$$

$$\text{Motor input} = 250 \times 25 = 6250\text{ w} \quad \text{Motor output} = 6250 - 1363 = 4887\text{ w} \quad T_{sh}$$

$$= 9.55 \times 4887 / 773 = 60.4\text{ N-m}$$

Speed control of DC motors:

The speed can be controlled by varying

1. flux/pole, ϕ (flux control)
2. resistance R_a of armature circuit (Rheistac control)

Speed control of shunt motors

1. Variation of flux or flux control method

$$N \propto 1/\phi$$

By decreasing the flux, the speed can be increased and vice versa. Hence the name flux or field control method. The flux of a dc motor can be changed by changing I_{sh} with the help of a shunt field rheostat.

1. A 250-v dc shunt motor has armature resistance of $0.25\ \Omega$ on load it takes an armature current of 50A and runs at 750 rpm. If the flux of motor is reduced by 10% without changing the load torque, find the new speed of the motor.

$$N_2/N_1 = E_{b2}/E_{b1} \times \phi_1/\phi_2 \quad T_a \propto \phi I_a \quad \text{Hence } T_{a1} \propto \phi_1 I_{a1}$$

$$T_{a2} \propto \phi_2 I_{a2}$$

Since $T_{a1} = T_{a2}$ $\therefore T_{a1} = k_2 I_a$.

$$k_2 = 0.9 k_1$$

$$50 k_1 = 0.9 k_1 I_{a2} \quad I_{a2} = 55.6 \text{ A}$$

$$E_{b1} = 250 - (50 \times 0.25)$$

$$= 231.1 \text{ V}$$

$$N_2/750 = 231.1/237.5 \times k_1/0.9 k_1 \quad N_2 = 81 \text{ rpm}$$

2. A 220 V shunt motor has an armature resistance of R_a . By how much must the main flux be reduced to raise the speed by 50% if the developed torque is constant.

$$N_2/N_1 = E_{b2}/E_{b1} \times k_1/k_2$$

Since torque remains constant, hence $k_1 I_{a1} = k_2 I_{a2}$

$$I_{a2} = I_{a1} k_1/k_2 = 40x$$

$$\text{When } x = k_1/k_2$$

$$E_{b1} = 220 - (40 \times 0.5)$$

$$= 200 \text{ V}$$

$$E_{b2} = 220 - (40x \times 0.5)$$

$$= 220 - 20x$$

$$N_2/N_1 = 3/2 \text{ (given)}$$

$$3/2 = [(220 - 20x)/200] \times X \quad x^2 - 11x + 15 = 0$$

$$k_1/k_2 = 1.6 \quad k_2/k_1 = 1/1.6 \quad (k_1/k_2)/k_1 = 1.6 - 1/1.6 = 3/8$$

$$\text{percentage change in flux} = 3/8 \times 100 = 37.5\%$$

2) Armature or rheostatic control method :

This method is used when speeds below the no-load speed are required. As the supply voltage is normally constant, the voltage across the armature is varied by inserting a variable rheostat or resistance in series with the armature circuit as shown. As controller resistance is increased, p.d. across the armature is decreased, thereby decreasing the armature speed for a load of constant torque, speed is approximately proportional to the p.d. across the armature.

From the speed/armature current characteristic it is such that greater the resistance in the armature circuit greater is the full in speed.

Let I_{a1} = armature current in the first case

I_{a2} = armature current in the second case

N_1, N_2 = corresponding speed; v = supply voltage

Then $N_1 \approx v - I_{a1} R_a$

$V \approx E_{b1}$

Let some controller resistance of value R be added to the armature circuit resistance so that its value becomes $(R + R_a) = R_t$

Then $N_2 \approx V - I_{a2} R_t$

$N_2/N_1 = E_{b2}/E_{b1}$

$N/N_0 = (V - I_a R_t) / (V - I_{a0} R_a)$

Neglecting $I_{a0} R_a$ w.r.t. v , we get

$N = N_0 (1 - I_a R_t/v)$

For a given resistance R_t the speed is a linear function of armature current I_a .

The load current for which the speed would be zero is found by putting $N = 0$ in the above relation

$0 = N_0 (1 - I_a R_t/v)$

$I_a = v/R_t$

This is the maximum current and is known as stalling current.

Losses in a DC motor: Losses in a Dc Motor are similar to that of a Dc Generator

TRANSFORMERS

Transformer is an ac machine; the main advantage of alternating currents over direct currents is that, the alternating currents can be easily transferable from low voltage to high or high voltage to low.

Alternating voltages can be raised or lowered as per the requirements in the different stages of electrical network as generation, transmission, distribution and utilization. This is possible with a device called transformer.

Definition:

Transformer is a static piece of apparatus by means of which electrical power is transferred from one alternating current circuit to another with the desired change in voltage or current and without any change in the frequency.

Principle of operation:

It is a static machine and it works on the principle of statically induced emf. It consists of:

³⁵₁₇ Magnetic circuit and

³⁵₁₇ Electric circuit

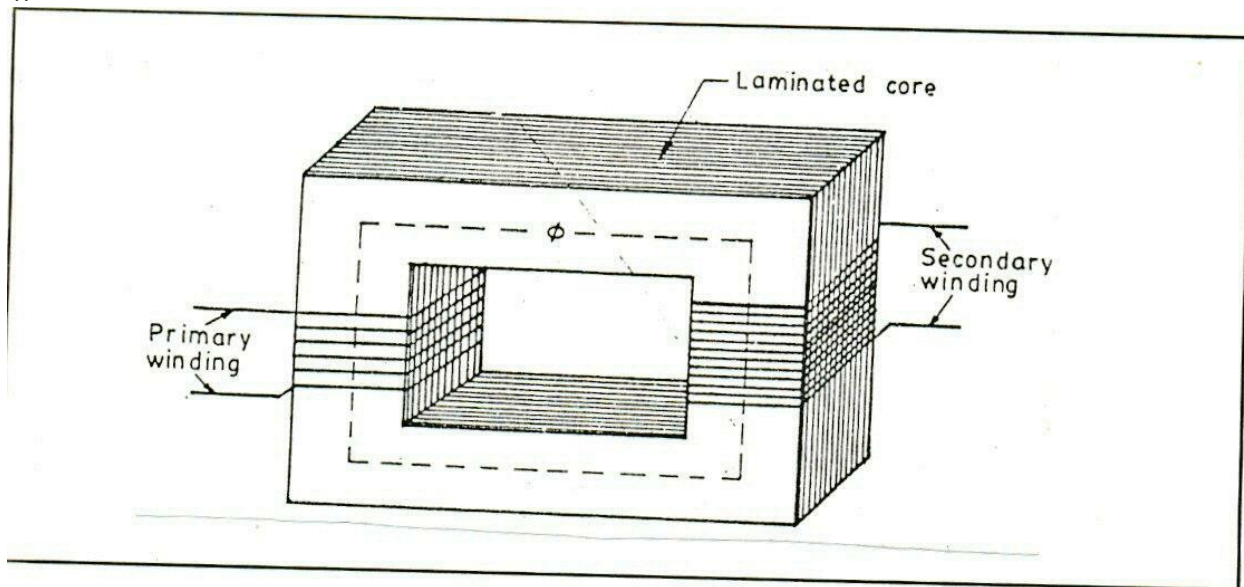

Two winding transformer

Two separate electrical windings are linked through a common magnetic circuit. The two electrical windings are isolated from each other.

The coil in which electrical energy is fed is called primary winding while the other from which electrical energy is drawn out is called secondary winding.

The primary winding has N_1 number of turns while secondary winding has N_2 number of turns.

When primary winding is excited by alternating voltage say V_1 , it circulates alternating current I_1 through it. This current produces an alternating flux ' ϕ ' which completes its path through the common magnetic core.

This flux links with both the windings. Because of this, it produces self induced emf E_1 in the primary winding while due to mutual induction i.e. due to flux produced by primary linking with secondary, it produces induced emf

E_2 in secondary winding.

These emf's are:

$$E_1 = -N_1 \frac{d\phi}{dt}$$

$$E_2 = -N_2 \frac{d\phi}{dt}$$

If now secondary circuit is closed through the load, the mutually induced emf in the secondary winding circulates current through the load. Thus electrical energy is transferred from primary to secondary with the help of magnetic core. A voltage V_2 appears across the load. Hence V_1 is the supply voltage, while V_2 is the secondary voltage when load is connected, then:

$$V_1 = N_1 \frac{d\phi}{dt} \quad \text{or} \quad V_2 = N_2 \frac{d\phi}{dt}$$

$$k = \frac{E_2}{E_1} = \frac{N_2}{N_1} \quad \text{Transformation ratio}$$

If $k > 1$, then $V_2 > V_1$, transformer is called step up transformer.

If $k < 1$, then $V_2 < V_1$, transformers is called step down transformers.

If $k = 1$, then $V_2 = V_1$, then transformer is called one to one transformer.

The current flowing through primary is I_1 and when load is connected current I_2 flows through secondary voltage. The power transfer from primary to secondary remains the same. Assuming both primary and secondary power factor to be the same, we can write:

Power input to primary = Power output from secondary

$$V_1 I_1 = V_2 I_2$$

Construction of a transformer:

There are basic parts of a transformer:

- (1) Magnetic core (2) Windings or coils (3) Tank or Body
- (4) Conservator Tank (5) Breather
- (6) Radiator
- (7) Bushings

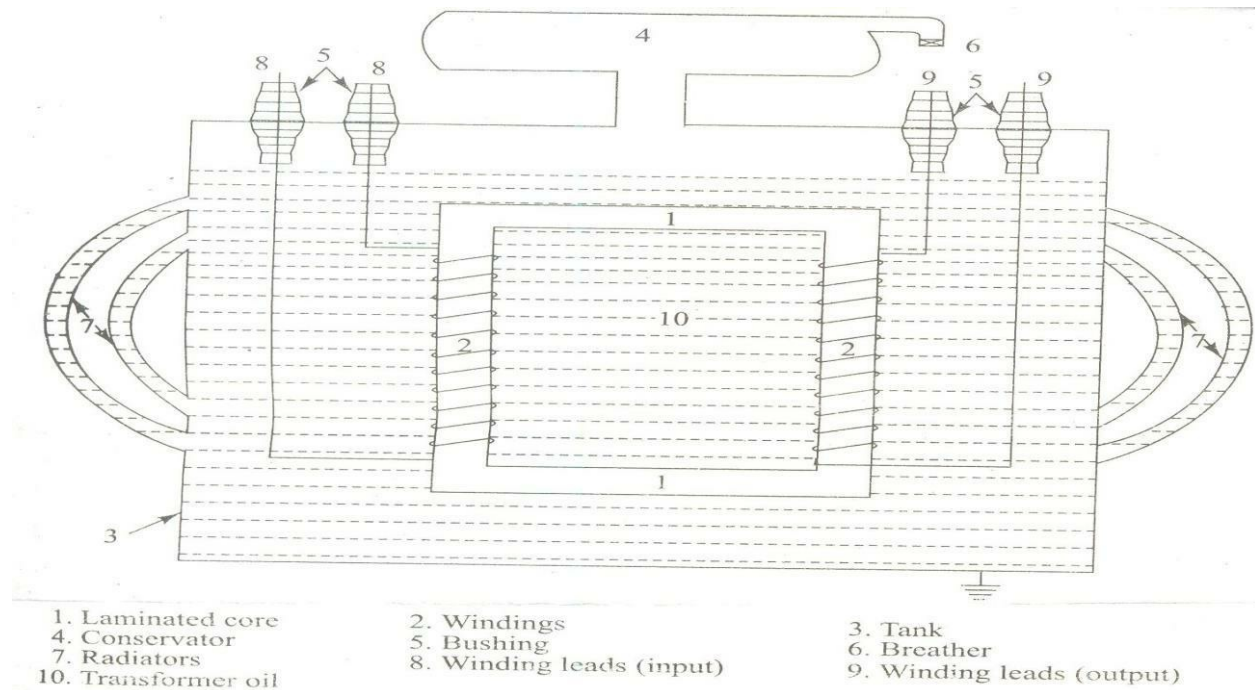

Core : The transformer core is made of silicon steel or sheet steel with 4 % silicon. The sheets are laminated and are coated with Oxide layer to reduce iron losses. The thickness of lamination is 0.35mm for 60 Hz and 5mm for 25Hz.

The core of the transformer is either square or rectangular in size. It is further divided in to two parts. The vertical portion on which coils are wound is called limb while the top and bottom horizontal portion is called yoke of the core.

The core is made up of laminations. Because of laminated type of construction, eddy current losses get minimized. Generally high-grade silicon steel laminations are used. These laminations are insulated from each other by using insulation like varnish.

The purpose of the core is to provide magnetic path of low reluctance between the two windings so that the total flux produced by one of the

winding will be linked fully with the other winding without any leakage.

Windings : A transformer has two windings. The winding which receives electrical energy is called Primary winding and the winding which delivers electrical energy is called Secondary winding. Windings are generally made up of High grade copper. The windings are provided with insulation so that one winding may not come in contact with the other winding. Generally cotton, Paper and Oxide layer is used as insulating medium.

Tank or Body : It is part which is meant to carry the transformer and the oil used in the transformer. The tank used for a transformer should be air tight so that moisture should also not enter into the tank so as to maintain the properties of the transformer oil.

Transformer Oil : It is the most important part of a transformer which decides the life of a transformer. The oil that is used in a transformer should be safe guarded properly so as to have a good life for a transformer.

Conservator Tank: When a transformer is oil filled and self cooled the oil in the tank is subjected to heat and thus will naturally expand and contract due to variations in the load current and is also subjected to seasonal variations. The conservator tank provides the means for the oil to settle down by expanding under heavy loads.

Breather: Transformer oil should not be exposed to atmosphere directly because it may absorb

Moisture and dust from the environment and may lose its electrical properties in a very short time. To avoid this from happening a breather is provided. The breather completely prevents the moisture and dust from coming into contact with the oil in the conservator tank when it expands or contracts.

Bushings : The purpose of Bushings is to provide proper insulation for the output leads to be taken out from the transformer tank. Bushings are generally of two types.

a) Porcelain type which are used for voltage ratings up to 33kV

b) Condenser type and Oil filled type are used for rating above 33kV

Radiator: These are meant to increase the surface area of the tank also to provide a path for the circulating of the transformer oil.

Types Of Transformers:

The transformers are classified based on the relative position or arrangement of the core & the windings, based on cooling and based on Voltage.

a) Based on arrangement of the core & the windings transformers are classified as

³⁵₁₇ Core type

³⁵₁₇ Shell type

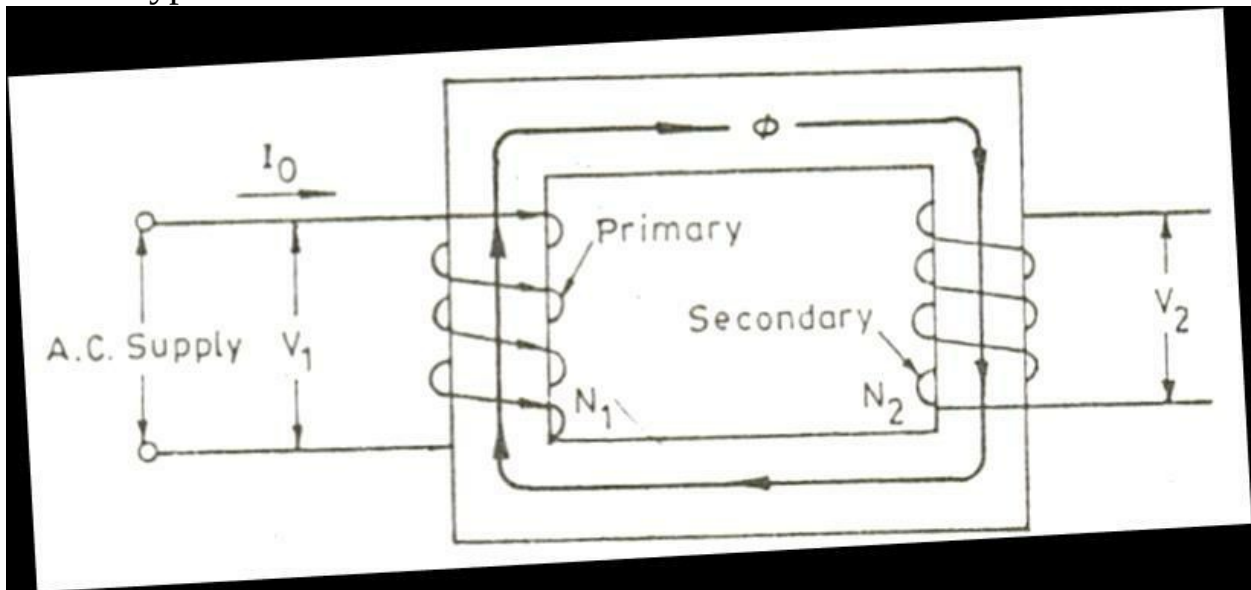

Core type Transformer

It has a single magnetic circuit. In this type, winding encircles the core, coils used are of cylindrical type. Such coils are wound in helical layers with different layers insulated from each other by paper, cloth, mica, etc. Core is made up of large number of thin laminations to reduce eddy current losses.

The windings are uniformly distributed over two limbs and hence natural cooling is more effective.

The coils can be easily removed by removing laminations of top yoke for maintenance.

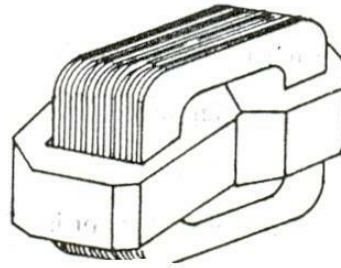
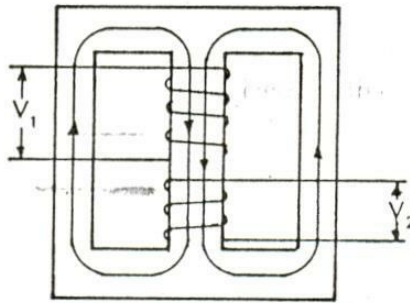

Shell type transformer

It has a double magnetic circuit. In this type core encircles the most part of the winding. The core is again laminated one and while arranging the laminations, care is taken that all joints at alternate layers are staggered.

This is done to avoid narrow air gap at the joint, right through the cross section of the core. Such joints are called as overlapped. The coils are multi-layered disc type or sandwich type coils and are placed on only one limb and are surrounded by the core. So natural cooling does not exist.

b)Based on Voltage

³⁵/₁₇ Step up

³⁵/₁₇ Step Down

Step up transformer is a transformer where the Output Voltage is greater than input Voltage i,e $V_2 > V_1$

Step down transformer is a transformer where the Output Voltage is less than input Voltage i,e $V_2 < V_1$

Transformation Ratio = $V_2/V_1 = N_2/N_1$

Where N_2, N_1 are number of turns in secondary and primary windings.

c)Based on cooling:

³⁵/₁₇ Oil cooled

³⁵/₁₇ Oil filled water cooled

³⁵/₁₇ Air cooled

EMF equation of a transformer:

Primary winding is excited by a voltage, which is alternating in nature. This circulates current through primary, which is also alternating and hence the flux produced is also sinusoidal in nature.

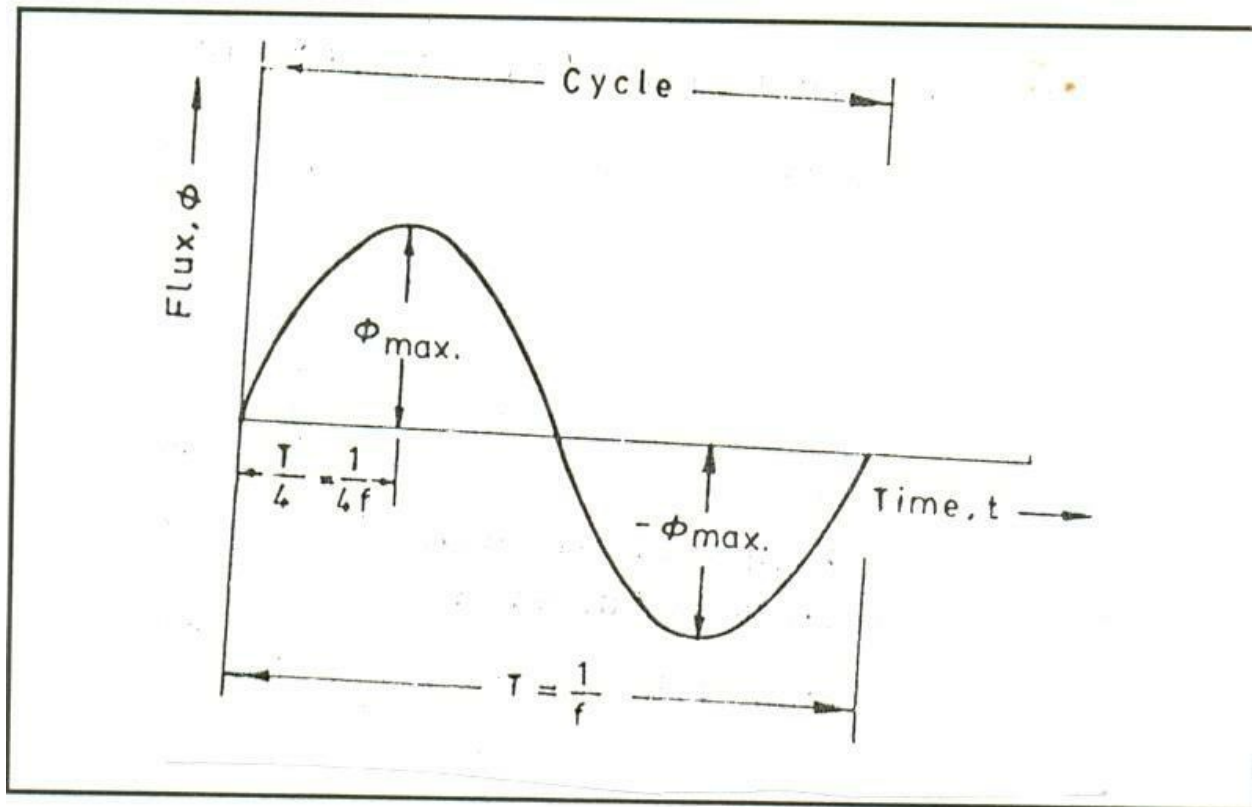

Variation of sinusoidal flux

Let ϕ = flux in the core

$$\phi_m = B_m \times A$$

N_1 = number of turns in the primary winding

N_2 = number of turns in the secondary winding

f = frequency of ac input in Hz.

The flux increases from its zero value to maximum value ϕ_m in one quarter of the cycle i.e., in $\frac{1}{4} f$ second.

ϕ

Average rate of change of flux $= \frac{m}{4f} = 4 f \phi_m \text{ wb/sec}$

Rate of change of flux per turn means induced emf in volts

Average emf / turn $= 4 f \phi_m$ volt.

If flux ϕ varies sinusoidally then rms value of induced emf is obtained by multiplying the average value with the form factor.

Form factor $= \frac{\text{rms value}}{\text{average value}} = 1.11$

rms value of emf/ turn $= 1.11 \times 4 f \phi_m = 4.44 f \phi_m$

Now rms value of induced emf

in the whole of primary winding $=$ induced emf / turn \times number of primary turns

$E_1 = 4.44 f N_1 \phi_m = 4.44 f N_1 B_m A$

Similarly, rms value of emf induced in secondary is:

$E_2 = 4.44 f N_2 \phi_m = 4.44 f N_2 B_m A$

$E_1 = E_2 = 4.44 f \phi_m$

N_1

N_2

N_m

N_2

That is, emf/ turn is same in both primary and secondary windings. In an ideal transformers on no load $V_1 = E_1$ & $E_2 = V_2$

Where, V_2 is the terminal voltage.

Ideal transformers

Transformer is called ideal if it satisfies the following properties:

1. It has no losses
2. Its windings have zero resistance
3. Leakage flux is zero i.e. 100% flux produced by primary links with the secondary
4. Permeability of core is so high that negligible current is required to establish the flux in it.

An ideal transformer is one which has no losses i.e., its windings have no ohmic resistance, there is no magnetic leakage and hence which has no I^2R

and core losses. In other words, **an ideal transformer consists of two purely inductive coils wound on a loss free core.**

Problems:

1. The maximum flux density in the core of a 250/3000 volts, 50 Hz single phase transformer is 1.2 wb/m^2 . If the emf per turn is 8 volt, determine a) primary and secondary turns B) area of the core

Solution: a) $E_1 = N_1 \times \text{emf induced / turn}$

$$N_1 = 250/8 = 32 \quad N_2 = 3000/8 = 375 \quad b) \quad E_2 = 4.44 f N_2 B_m A$$

$$3000 = 4.44 \times 50 \times 375 \times 1.2 \times A$$

$$A = 0.03 \text{ m}^2.$$

2. A single phase transformer has 400 primary and 1000 secondary turns. The net cross sectional area of the core is 60 cm^2 . If the primary winding be connected to a 50 Hz supply at 520 V, calculate:

a) peak value of flux density in the core b) the voltage induced in the secondary winding.

$$\text{Solution: } K = N_2/N_1 = 1000/400 = 2.5$$

$$a) \quad E_2/E_1 = k \quad E_2 = k E_1 = 2.5 \times 520 = 1300 \text{ V}$$

$$b) \quad E_1 = 4.44 f N_1 B_m A \quad 520 = 4.44 \times 50 \times 400 \times B_m \times 60 \times 10^{-4}. \quad B_m = 0.976 \text{ wb/m}^2.$$

3. A 25 KVA transformer has 500 turns on the primary and 50 turns on the secondary winding. The primary is connected to 3000V, 50 Hz supply. Find the full load primary and secondary currents, the secondary emf and the maximum flux in the core. (Neglect leakage drops and no load primary current).

Solution:

K

\uparrow

$$N_2 \uparrow 50 \uparrow 1$$

$$N_1 = 500 \quad 10$$

$$\text{Full load } I_2 = \frac{25000}{3000} = 8.33 \text{ A}$$

$$\text{Full load } I_1 = I_2 / K = 10 \times 8.33 = 83.3 \text{ A}$$

$$\text{emf per turn on primary side} = 3000 / 500 = 6 \text{ V}$$

$$\text{Secondary emf} = 6 \times 50 = 300 \text{ v (or } E_2 = K E_1 = 3000 \times 1/10 = 300 \text{ v)}$$

$$E_1 = 4.44 f N_1 \phi_m$$

$$3000 = 4.44 \times 50 \times 500 \times \phi_m$$

$$\phi_m = 27 \text{ mwb}$$

Transformer on No-load:

An ideal transformer is one in which there were no core losses and copper losses. But practical conditions require that certain modifications be made in the foregoing theory. When an actual transformer is put on load, there is iron loss in the core and copper loss in the winding (both primary and secondary) and these losses are not entirely negligible.

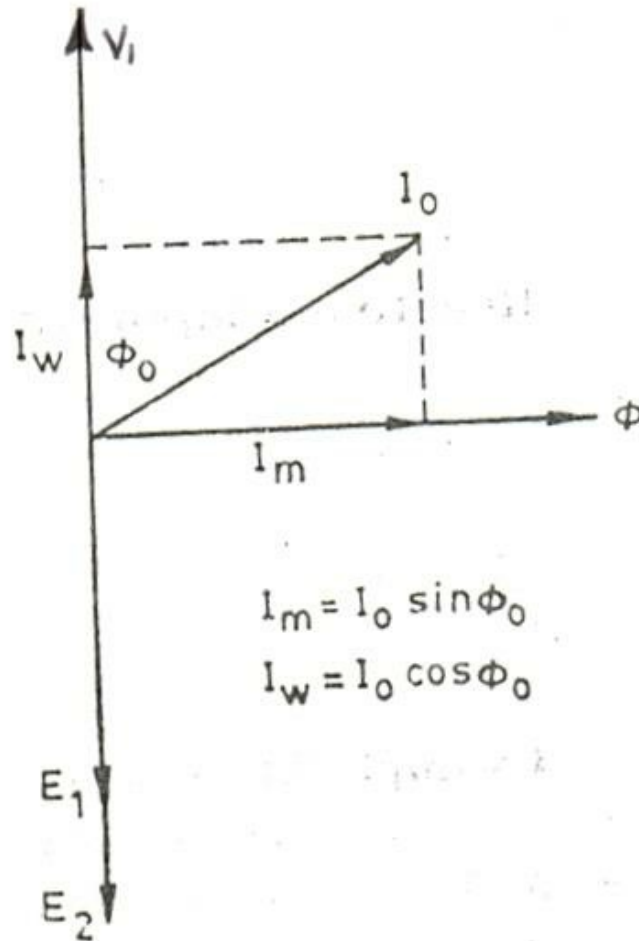

No load vector diagram

Even when the transformer is on no-load the primary input current is not wholly reactive.

The primary input current under no load conditions has to supply (1) iron losses in the core i.e. hysteresis loss and eddy current loss and (2) a very small amount of copper loss in primary (there being no copper loss in secondary as it is open).

Hence, the no load primary input current I_0 is not at 90° behind V_1 but lags it by an angle $\phi_0 < 90^\circ$. No load input power $W_0 = V_1 I_0 \cos \phi_0$, Where $\cos \phi_0$ is primary power factor under no load condition.

The primary current I_0 has two components:

(1) One in phase with V_1 . This is known as active or working or iron loss component I_w because it mainly supplies the iron loss plus a small quantity of primary copper loss.

$$I_w = I_0 \cos \phi_0.$$

(2) The other component is in quadrature with V_1 and is known as magnetizing component I_m because its function is to sustain the alternating flux in the core. It is watt-less.

$$I_m = I_0 \sin \phi_0$$

Obviously, I_0

is the vector sum of I_w

and I_m .

hence I_0^2

$$= I_w^2 + I_m^2$$

The following points should be noted carefully.

1. The no-load primary current I_0 is very small as compared to the full-load primary current. It is about 1 percent of the full load current.

2. Owing to the fact that the permeability of the core varies with the instantaneous value of the exciting or magnetizing current is not truly sinusoidal. As such, it should not be represented by a vector because only sinusoidally varying quantities are represented by rotating vectors.

3. As I_0 is very small, the no load primary copper loss is negligibly small which means that **no load primary input is practically equal to the iron loss in the transformer.**

4. As it is principally, the core loss which is responsible for shift in the current vector, angle ϕ_0 is **known as hysteresis angle** of advance.

Problem:

a) A 2,200/200-V transformer draws a no load primary current of 0.6 A and absorbs 400 watts. Find the magnetizing and iron loss currents.

b) A 2200 / 250-V transformer takes 0.5 A at a p.f. of 0.3 on open circuit. Find magnetizing and working component of no-load primary current.

a)

Iron – loss current =

no load input in watts $V_1 I_o \cos \phi_0$ primary voltage $V_1 I_w = 400/2200 =$

0.182 A

Now

I

$I^2 R \approx I^2 R_w \approx$

**Magnetizing component $I_{\neq} =$
 $\sqrt{0.6^2 - 0.182^2} \approx 0.572 \text{ A}$**

c) $I_0 = 0.5$

$\cos \varphi_0 = 0.3$

$I_w = I_0 \cos \varphi_0 = 0.5 \times 0.3 = 0.15 \text{ A}$

$$I_{\neq} = \sqrt{0.5f^2 + 0.15f^2} \approx 0.476 \text{ A}$$

Transformer on load:

When the secondary is loaded, the secondary current I_2 is set up. The magnitude and phase of I_2 w.r.t. V_2 is determined by the characteristics of load. Current I_2 is in phase with V_2 if load is non-inductive, it lags if load is inductive and it leads if load is capacitive. The secondary current sets up its own mmf ($N_2 I_2$) and hence its own flux ϕ_2 which is in opposition to the main flux ϕ which is due to I_0 .

The secondary ampere turns $N_2 I_2$ are known as demagnetizing ampere turns. The opposing secondary flux ϕ_2 weakens the primary flux ϕ hence primary back emf E_1 tends to be reduced. For a moment V_1 gains the upper hand over E_1 and hence causes more current to flow in primary. Let the additional primary current be I_{21} . It is known as load component of primary current. This current is in antiphase with I_2 .

The additional primary mmf $N_1 I_{21}$ sets up its own flux ϕ_{21} which is in opposition to ϕ_2 (but is in the same directions as ϕ) and is equal to it in magnitude. Hence, the two cancel each other out. So, the magnetic effects of secondary current I_2 are immediately neutralized by the additional primary current I_{21} which is brought into existence exactly at the same instant as I_2 .

Hence whatever the load conditions, the net flux passing through the core is approximately the same as at no load.

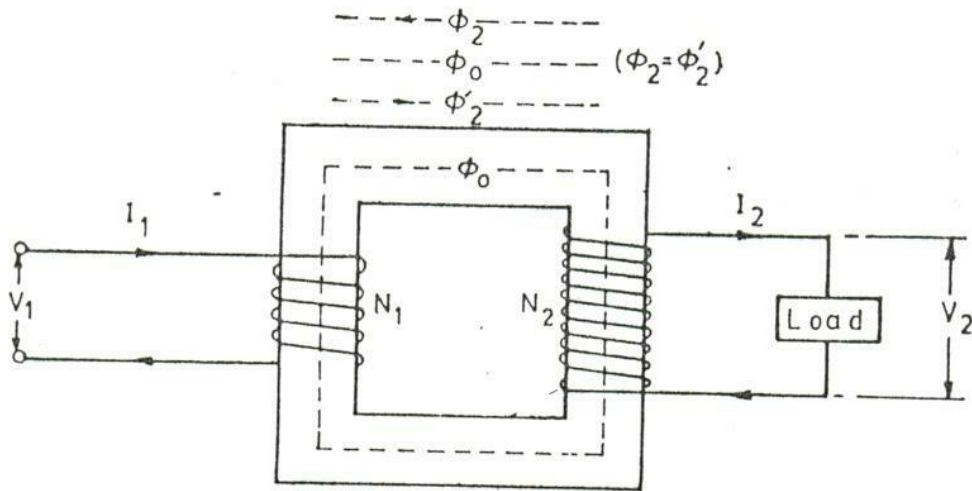

Transformer on load

$$k_2 = k_{21}$$

$$N_2 I_2 = N_1 I_{21}$$

I

$$I \uparrow N_2$$

$$2 \times I_2 \uparrow k I_{2N1}$$

Hence, when transformer is on load the primary winding has two currents in it; one is I_0 and the other is I_{21} which is anti-phase with I_2 and k times in magnitude. The total primary current is the vector sum of I_0 and I_{21} .

I_1

$$I_2' = KI_2 I_0$$

$$I \approx I_w$$

The vector diagrams for a loaded transformer when load is non-inductive, inductive and when it is capacitive is shown. Voltage transformation ratio of unity is assumed so that primary vectors are equal to secondary vectors.

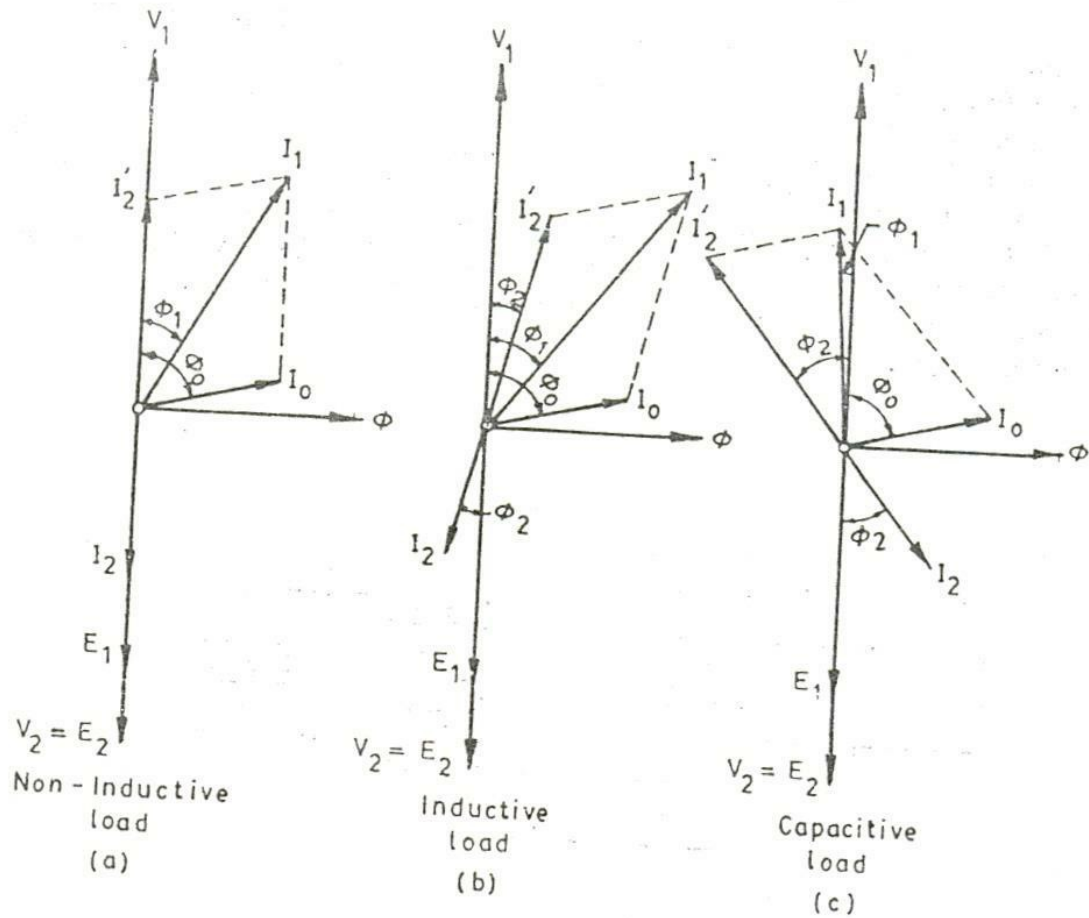

Vector Diagrams of a loaded transformer

With reference to the fig. (a) I_2 is secondary current in phase with E_2 (it should be v_2). It causes primary current I_{21} which is anti-phase with it and equal to it in magnitude ($k = 1$). The total primary current I_1 is the vector sum of I_0 and I_{21} and lags behind V_1 by an angle ϕ_1 .

In (b) vectors are drawn for an inductive load. Here I_2 lags E_2 (actually V_2) by ϕ_2 . Current I_{21} is again in anti-phase with I_2 and equal to it in magnitude. I_1 is the vector sum of I_{21} and I_0 and lags behind V_1 by ϕ_1 . In (c) vectors are drawn for a capacitive load.

In (b) vectors are drawn for an inductive load. Here I_2 lags E_2 (actually V_2) by ϕ_2 . Current I_{21} is again in anti-phase with I_2 and equal to it in magnitude. I_1 is the vector sum of I_{21} and I_0 and lags behind V_1 by ϕ_1 . In (c) vectors are drawn for a capacitive load.

Problems:

A single phase transformer with a ratio of 440/110-V takes a no-load current of 5A at 0.2 p.f. lagging. If the secondary supplies a current of 120 A at a p.f. of 0.8 lagging, estimate the current taken by the primary.

$$\cos \phi_2 = 0.8$$

$$\phi_2 = \cos^{-1}(0.8) = 36^\circ 54'$$

$$\cos \phi_0 = 0.2 \quad \text{Now } K = V_2 / V_1 = 110/440 = 1/4$$

$$I_{21} = K I_2 = 120 \times 1/4 = 30 \text{ A}$$

$$I_0 = 5 \text{ A}$$

Angle between I_0 & I_{21}

$$78^\circ 30' - 36^\circ 54' = 41^\circ 36'$$

Using parallelogram law of vectors, we get

$$I_1 = \sqrt{5^2 + 30^2 - 2 \times 5 \times 30 \times \cos 41^\circ 36'} = 34.45 \text{ A}$$

Transformer with winding resistance but no magnetic leakage:

An ideal transformer possesses no resistance, but in an actual transformer, there is always present some resistance of the primary and secondary windings. Due to this resistance, there is some voltage drop in the two windings. The result is that

1. The secondary terminal voltage V_2 is vectorially less than the secondary induced emf E_2 by an amount $I_2 R_2$ where R_2 is the resistance of the secondary winding. Hence, V_2 is equal to vector difference of E_2 and resistance voltage drop $I_2 R_2$.

$$V_2 = E_2 - I_2 R_2$$

2. Similarly primary induced emf E_1 is equal to the vector difference of V_1 and $I_1 R_1$ where R_1 is the resistance of the primary winding.

$$E_1 = V_1 - I_1 R_1$$

Transformer with resistance and leakage reactance:

The primary impedance:

Z

↑

↑

$$R_{11}^2 \dot{I}_1^2$$

11

The secondary impedance:

Z

2

I

$$R_{22}^2 \dot{I}_2^2$$

22

The resistance and leakage reactance of each winding is responsible for some voltage drop in each winding.

In primary, the leakage reactance drop is $I_1 X_1$, hence

$$V_1 = E_1 + I_1 (R_1 + jX_1) = E_1 + I_1 Z_1. \quad E_1 = V_1 - I_1 Z_1.$$

$$(R_2 + jX_2)$$

$$= V_2 + I_2 Z_2 \quad V_2 = E_2 - I_2 Z_2.$$

The vector diagrams for such a transformer for different kinds of loads are shown, in the diagrams, vectors for resistive drops are drawn parallel to current vectors whereas reactive drops are drawn perpendicular to current vectors.

Vector Diagram

Steps to draw vector diagram:

1. Draw a horizontal line to represent flux line and a vertical line to represent voltage axis.
2. Draw a line OA in the III quadrant at some inclination to represent V_2 the terminal voltage.
3. Let I_2 be the load current in line with V_2 (resistive load)
4. At the tip of V_2 , draw AB parallel to I_2 to represent $I_2 R_2$ drop (in line with V_2)
5. At 'B' draw BC at right angles to AB to represent $I_2 X_2$ meeting the vertical line at 'C' then OC is equal to secondary induced emf E_2 .
6. Produce 'O' backwards to 'D' such that $OD = OC/k$ then OD represents the primary induced emf.
7. Produce the current line I_2 backwards to F such that $OF = KI_2$. Let 'OE' be equal to the load current ' I_0 ' at angle of ' ϕ_0 ' from E_1 .
8. Construct the parallelogram OEGF then OG represents the primary current

I_1 .

9. At the tip of E_1 i.e. at D, draw DH equal to $I_1 R_1$, parallel to OG. At 'H' draw 'HJ' perpendicular to DH to $I_1 X_1$ drop

10. V_1 is obtained by adding vectorially the impedance drop $I_2 Z_2$ to $-E_1$.

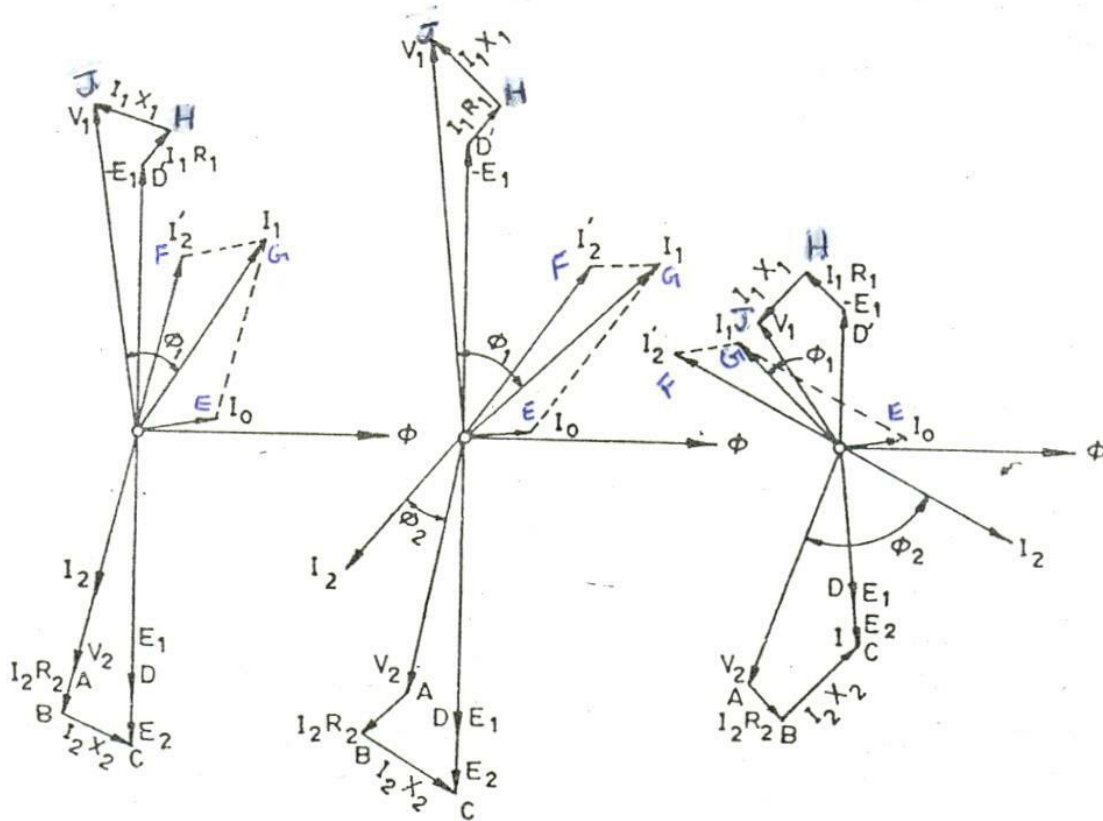

Vector Diagrams of a Loaded Transformer

Equivalent Resistance:

A transformer with primary and secondary winding resistance of R_1 and R_2 can be transferred to any one of the two windings. The advantage of concentrating both the resistances in one winding is that it makes calculations very simple and easy because one has then to work in one winding only.

A resistance of R_2 in secondary is equivalent to R_2/k^2 in primary. The value R_2/k^2 will be denoted by R_2' — the equivalent secondary resistance as referred to primary.

The copper loss in the secondary is $I_2^2 R_2$. This loss is supplied by the primary which takes a current of I_1 . Hence, if R_{21} is the equivalent resistance in primary which would have caused the same loss as R_2 in secondary, then

$$I_1^2 R_{21} = I_2^2 R_2 \quad R_{21} = (I_2/I_1)^2 R_2.$$

If no load current I_0 is neglected, then $I_2/I_1 = 1/k$

$$\text{Hence, } R_{21} = R_2/k^2$$

Similarly equivalent primary resistance as referred to secondary is $R_{11} = k^2 R_1$.

The resistance $R_1 + R_{21} = R_1 + R_2/k^2$ is known as the equivalent or effective resistance of the transformer as referred to primary and is designated as

$$\mathbf{R_{01} = R_1 + R_{21} = R_1 + R_2/k^2.}$$

Similarly the equivalent resistance of the transformer as referred to secondary

$$\mathbf{R_{02} = R_2 + R_{11} = R_2 + k^2 R_1.}$$

1. When shifting resistance to secondary multiply it by k^2 . 2. When shifting resistance to primary, divide by k^2 .

Leakage Reactance:

Leakage Reactance can also be transferred from one winding to the other in the same way as resistance.

$$X_{01}' \text{ and } X_{01}' \div k^2 \quad X_{01} \text{ and } X_{01} \div k^2 \quad X_{01}' \text{ and } X_{01}' \div k^2 \quad X_{01} \text{ and } X_{01} \div k^2$$

X_{01}'

X_{01}

X_{01}'

X_{01}

X_{01}'

X_{01}

X_{01}'

$$X_{01}' \text{ and } X_{01}' \div k^2$$

X_{01}

Total impedance

Z_{01}

Z_{01}

Z_{01}'

Z_{01}

$$Z_{01}' \text{ and } Z_{01}' \div k^2 \quad Z_{01} \text{ and } Z_{01} \div k^2$$

01 01 02 02

Total impedance transferred to primary and secondary side

Example: A 30 KVA, 2400/120 V, 50 Hz transformer has a high voltage winding resistance of $0.1 \ \Omega$ and leakage reactance of $0.22 \ \Omega$ the low voltage winding resistance is $0.035 \ \Omega$ and the leakage reactance is $0.012 \ \Omega$, find the equivalent winding resistance, reactance and impedance as referred to

(a) high voltage side (b) low-voltage side

$$K = 120/2400 = 1/20$$

$$R_1 = 0.1 \ \Omega \quad X_1 = 0.22 \ \Omega \quad R_2 = 0.035 \ \Omega \quad \text{and} \quad X_2 = 0.012 \ \Omega$$

a) high voltage side is the primary side

Hence values as referred to primary side are

R

o

1

\rightarrow

R

1

\hat{G}

R

$$1 \rightarrow R_1 \hat{G} R_2 \rightarrow 0.1 \hat{G} 0.035$$

$$\hat{G} 1/20 \hat{G} 2 \rightarrow 14.1 \ \Omega_{2k2}$$

X

o

1

\rightarrow

X

1

\hat{G}

X

$$1 \rightarrow X_1 \hat{G} X_2 \rightarrow 0.22 \hat{G} 0.12$$

$$\hat{G} 1/20 \hat{G} 2 \rightarrow 5.02 \ \Omega_{2k2}$$

$$Z_{01} \rightarrow R^2 \hat{G} X^2 \hat{G} 14.1^2 \hat{G} 5.02^2 \rightarrow 15 \ \Omega_{0101}$$

$$b) R_{o2} \rightarrow R_2 \hat{G} R_1 \rightarrow R_2 \hat{G} k^2 R_1 \rightarrow 0.035 \hat{G} 1/20 \hat{G} 2 \times 0.1 = 0.03525 \ \Omega_1$$

$$X_{o2} \rightarrow X_2 \hat{G} X_1 \rightarrow X_2 \hat{G} k^2 X_1 \rightarrow 0.012 \hat{G} 1/20 \hat{G} 2 \times 0.22 = 0.01255 \ \Omega_1$$

$$Z_{02} = R^2 + X^2 = 0.325^2 + 0.01255^2 = 0.0374 \text{ } \Omega_{02}$$

$$Z_{02} = k^2 Z_{01} = \frac{1}{20^2} \times 15 = 0.0375 \text{ } \Omega$$

Equivalent circuit:

The transformer shown in (a) is resolved into an equivalent circuit in which the resistance and leakage reactance of the transformer are imagined to be external to the winding whose only function is to transform the voltage. The no-load current I_0 consists of two components, I_w and I_{ϕ} therefore, I_0 is splitted into two parallel branches. The current I_{ϕ} accounts for the core-loss and hence is shown to flow through resistance R_0 . The current I_{ϕ} represents magnetizing component and is shown to flow through a pure reactance X_0 . The value of E_1 is obtained by subtracting vectorially $I_1 Z_1$ from V_1 .

$$X_0 = E_1 / I_{\phi} \text{ and } R_0 = E_1 / I_w$$

E_1 & E_2 are related to each other by the expression $E_2 / E_1 = N_2 / N_1 = k$

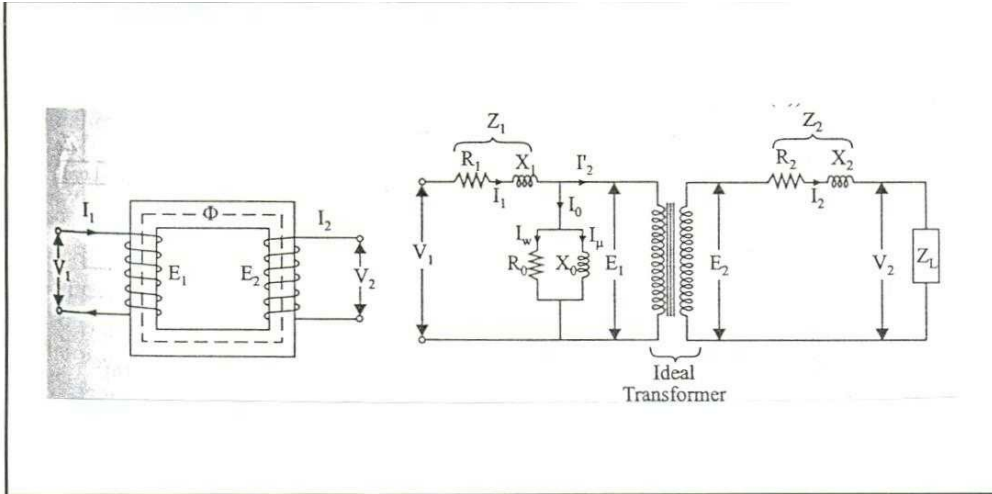

To make transformer calculations simple, it is preferable to transfer voltage, current and impedance either to the primary or to the secondary. The primary equivalent of the secondary induced voltage is $E_2' = E_2/K = E_1$. Similarly, primary equivalent of secondary terminal and output voltage is $V_2' = V_2/K$. Primary equivalent of the secondary current $I_2' = KI_2$. For transferring secondary impedance to primary, K^2 is used

$$R_2' = R_2/K^2 \quad X_2' = X_2/K^2 \quad Z_2' = Z_2/K^2$$

A simplified equivalent circuit of a transformer, as referred to primary side is shown. A simplification can be made by transferring the exciting circuit across the terminal as below:

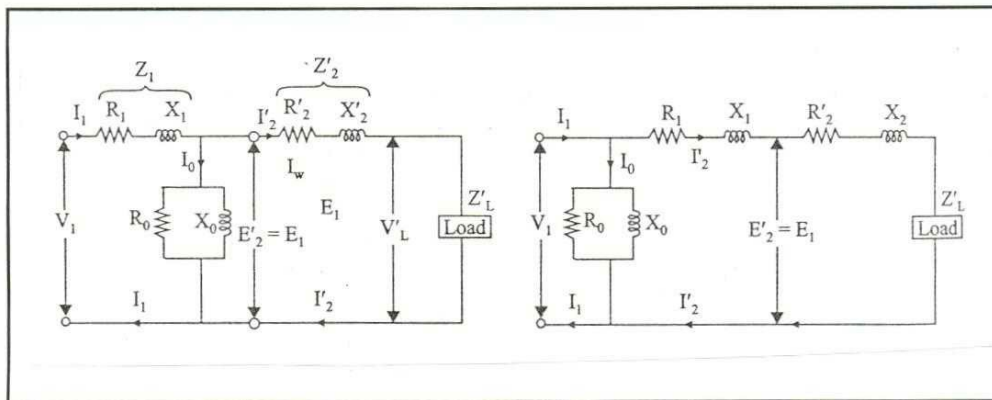

Further simplification may be achieved by omitting I_0 altogether as shown below: $W = V_1 I_0 \cos \phi_0$. $\cos \phi_0 = W/V_1 I_0$ $I_w = I_0 \sin \phi_0$

$$I_w = I_0 \cos \phi_0$$

$$X_0 = V_1/I_w \quad \& \quad R_0 = V_1/I_w$$

$$I_0 = V_1 Y_0$$

$$Y_0 = I_0/V_1$$

G_0 is given equation $W = V_{12} G_0 G_0 = W/V_{12}$

$$2\dot{H} G^2 B_0 = Y_{00}$$

Short-circuit or Impedance Test:

In this test, one winding usually the **low-voltage winding is solidly short – circuited by a thick conductor.**

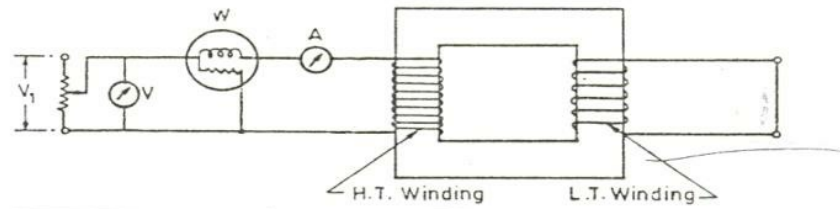

This method is used to find the following parameters.

1. Equivalent impedance (Z_{01} or Z_{02}), leakage reactance (X_{01} or X_{02}) and total resistance (R_{01} or R_{02}) of the transformer as referred to the winding in which the measuring instruments are placed.
2. Cu loss at full-load (at any desired load). This loss is used in calculating the efficiency of the transformer.
3. Knowing Z_{01} or Z_{02} , the total voltage drop in the transformer as referred to primary or secondary can be calculated and hence regulation of the transformer determined.

A low voltage at correct frequency is applied to the primary and is cautiously increased till full-load currents are flowing both in primary and secondary. Since, in this test the applied voltage is a small percentage of the normal voltage, the mutual flux \dot{H} produced is also a small percentage of its normal value. Hence, core losses are very small with the result that the wattmeter reading represents the full load copper loss or $I^2 R$ loss for the whole transformer i.e. both primary copper loss and secondary copper loss.

If V_{sc} is the voltage required to circulate rated load currents, then $Z_{01} = V_{sc} /$

I_1 Also, $W = I_{12} R_{01} R_{01} = W/I_{12}$

X

₀₁

=

Z

$2 \dot{H}_R^2 01 01$

Losses in the transformer:

Losses that occur in a transformer are:

³⁵₁₇ Core or iron losses ³⁵₁₇ Copper losses

Core losses:

It includes both the hysteresis loss and eddy current loss. These losses are minimized by using steel of high silicon content for the core and by using very thin laminations.

Iron or core loss is found from the O.C test. The input of the transformer when on no-load measures the core loss.

Hysteresis loss:

When a magnetic material is subjected to repeated cycles of magnetization and demagnetization it results into disturbance and there will be loss of energy and this loss of energy appears as heat in the magnetic material. This is called as hysteresis loss.

Hysteresis loss = $k_h B_{m1.6} f \times \text{volume, watts}$

Where, $K_h = \text{constant}$

$B_m = \text{maximum flux density}$ $f = \text{frequency}$

The hysteresis loss can be reduced by using thin laminations for the core.

Eddy current loss:

Due to alternating fluxes linking with the core, eddy currents get induced in the laminations of the core. Such eddy currents cause the eddy current loss in the core and heat up the core.

Eddy current loss can be reduced by selecting high resistivity material like

silicon. The most commonly used method to reduce this loss is to use laminated construction to construct the core. Core is constructed by stacking thin pieces known as laminations. The laminations are insulated from each other by thin layers of insulating material like varnish, paper, mica. This restricts the paths of eddy currents, to respective laminations only. So area through which currents flow decreases, increasing the resistance and magnitude of currents gets reduced.

Eddy current loss = $K_e B_m^2 f^2 t^2$, watts

Where, K_e = constant

B_m = maximum flux density f = frequency

t = thickness of the laminations

Copper loss:

This loss is due to the ohmic resistance of the transformer windings.

Total copper loss = $I_{12} R_1 + I_{22} R_2 = I_{12} R_{01} = I_{22} R_{02}$

Copper loss is proportional to (current)² or (KVA)²

Copper loss at half the full-load is one fourth of that at full-load.

Efficiency:

output / *input*

$\frac{\text{output}}{\text{input}} = \frac{\text{input} - \text{Cu.loss} - \text{Ironloss}}{\text{input}}$

$\frac{\text{output}}{\text{input}} = \frac{\text{input} - \text{losses}}{\text{input}}$

Copper loss = $I_{12} R_{01}$ or $I_{22} R_{02} = W_{cu}$

Iron losses = hysteresis loss + eddy current loss = $W_h + W_e = W_i$

primary input = $V_1 I_1 \cos \phi_1$

ϕ_1

$\frac{W_{cu}}{V_1 I_1 \cos \phi_1}$

$\frac{W_i}{V_1 I_1 \cos \phi_1}$

$\frac{W_h}{V_1 I_1 \cos \phi_1}$

$\frac{W_e}{V_1 I_1 \cos \phi_1}$

$\frac{W_{cu}}{V_1 I_1 \cos \phi_1}$

$\frac{W_i}{V_1 I_1 \cos \phi_1}$

$\frac{W_{cu}}{V_1 I_1 \cos \phi_1} = \frac{I_{12}^2 R_{01}}{V_1 I_1 \cos \phi_1} = \frac{I_{12}^2 R_{01}}{V_1 I_1 \cos \phi_1}$

$\frac{W_i}{V_1 I_1 \cos \phi_1} = \frac{W_h + W_e}{V_1 I_1 \cos \phi_1}$

$\frac{W_h}{V_1 I_1 \cos \phi_1}$

$$\begin{aligned}
 & \frac{1}{I} \\
 & \frac{1}{\cos} \\
 & \frac{1}{V_1 I_1 \cos} \\
 & \frac{1}{I} \\
 & \frac{1}{I} \\
 & I_1 R_{01} + W_i V \\
 & \frac{1}{I} \\
 & \frac{1}{\cos} \\
 & \frac{1}{V_1 \cos}
 \end{aligned}$$

Differentiating both sides with respect to I_1 , we get

$$\frac{R_{01} W_i dI_1}{d \cos} = -V_1 \cos^2 + V_1 I^2 \cos$$

For \cos to be maximum, $\frac{d \cos}{dI_1} = 0$. Hence

$$\begin{aligned}
 & W_i \\
 & \text{or} \\
 & W_i = I_1^2 R_{01} \text{ or } I_2^2 R_{02} V_1 \\
 & \frac{R_{01}}{V_1} = \frac{I_2^2 R_{02}}{V_1}
 \end{aligned}$$

$$\frac{\cos}{I}$$

Cu loss = Iron loss

The output current corresponding to maximum efficiency is I_2

$$\begin{aligned}
 & = \\
 & \star W_i \\
 & \star \\
 & \star \\
 & i
 \end{aligned}$$

$$\star R_{02} \star$$

It is this value of output current, which will make the Cu-loss equal to the iron loss.

1. If we are given iron loss and full load Cu loss, then the load at which two losses would be equal

Full
load

x

Iron loss $F.L.cu$ loss

2. Efficiency at any load

∞

†

(x * full

$x * full \text{ } \frac{W_{cu}}{W_{cu} + W_i} \times 100$

Transformer rating in KVA:

Cu loss of a transformer depends on current and iron loss on voltage. Hence, total transformer loss depends on volt-ampere (VA) and not on phase angle between voltage and current i.e., it is independent of load power factor. That is why rating of transformer is in KVA and not in KW.

Regulation of a Transformer

(1) When a transformer is loaded with a constant primary voltage, the secondary voltage decreases because of its internal resistance and leakage reactance.

Let, ${}_0V_2$ = secondary terminal voltage at no-load = $E_2 = KE_1 = KV_1$ because at no-load the impedance drop is negligible.

V_2 = secondary terminal voltage on full-load

The change in secondary terminal voltage from no - load to full-load is ${}_0V_2 - V_2$. This change divided by ${}_0V_2$ is known as regulation 'down'. If this change is divided by V_2 i.e., full-load secondary terminal voltage, then it is called regulation 'up'.

% regulation 'down' = $\frac{{}_0V_2 - V_2}{{}_0V_2} \times 100$

V_2

% regulation 'up' = $\frac{V_2 - V_2'}{V_2} \times 100$

In further treatment, unless stated otherwise, regulation is to be taken as regulation 'down'.

The change in secondary terminal voltage from no-load to full-load, expressed as a percentage of no-load secondary voltage, is:

= $V_r \cos \phi + V_x \sin \phi$ (approximately)

where V_r = percent resistive drop = $100 \times \frac{I^2 R}{V_2}$ V_x = percent reactive drop = $100 \times \frac{I^2 X}{V_2}$

or more accurately = $(V_r \cos \phi + V_x \sin \phi) + \frac{1}{200} (V_x \cos \phi - V_r \sin \phi)^2$

% regulation = $V_r \cos \phi + V_x \sin \phi$

(2) The regulation may also be explained in terms of primary values.

The secondary no-load terminal voltage as referred to primary is $E_{21} = E_2/K = E_1 = V_1$ and if the secondary full-load voltage as referred to primary is $V_{21} (= V_2/K)$

% regulation = $\frac{V_1 - V_{21}}{V_1} \times 100$

If angle between V_1 and V_{21} is neglected, then the value of numerical difference $V_1 - V_{21}$ is given by $(I_1 R_{01} \cos \phi + I_1 X_{01} \sin \phi)$ for lagging p.f.

% regulation = $\frac{I_1 R_{01} \cos \phi + I_1 X_{01} \sin \phi}{V_1} \times 100$

where,

$I_1 R_{01} \times 100 = V_r$ and $I_1 X_{01} \times 100 = V_x$

if angle between V_1 and V_{21} is not negligible, then % regulation =

É

í í

v

r

cos

¼

238
93

v

x

sin

¼

Ĝ

$$I_1 V_x \cos \theta \approx V_r \sin \theta \approx 200$$

Problem 1:

Obtain the equivalent circuit of a 200/400-V,50Hz, 1-phase transformer from the following test data.

O.C. test: 200V, 0.7A, 70 W on low voltage side S.C. test: 15V, 10A, 85 W on high voltage side

Calculate the secondary voltage when delivering 5KW at 0.5 p.f. lagging, the primary voltage being 200V.

Solution:

$$V_1 I_0 \cos \theta_0 = W_0$$

$$200 \times 0.7 \times \cos \theta_0 = 70w$$

$$\cos \theta_0 = 0.5 \sin \theta_0 = 0.866$$

$$I_w = I_0 \cos \theta_0 = 0.7 \times 0.5 = 0.35A$$

$$I_{\neq} = I_0 \sin \theta_0 = 0.7 \times 0.866 = 0.606A$$

$$R_0 = V_1 / I_w = 200 / 0.35 = 571.4\Omega$$

$$X_0 = V_1 / I_{\neq} = 200 / 0.606 = 330\Omega$$

From S.C. Test:

$$Z_{02} = V_{sc} / I_2 = 15 / 10 = 1.5\Omega$$

$$Z_{01} = Z_{02} / K^2 = 1.5 / 4 = 0.375\Omega$$

$$I_2 R_{02} = W; R_{02} = 85/100 = 0.85 \text{ } \Omega$$

$$X_{01} = Z^2 \frac{R^2}{R^2} = 0.31 \text{ } \Omega$$

$$X_{02} = Z^2 \frac{R^2}{R^2} = 1.24 \text{ } \Omega$$

$$\begin{aligned} \text{Total transformer drop as referred to secondary} &= I_2 (R_{02} \cos \phi_2 + X_{02} \sin \phi_2) \\ &= 15.6 (0.85 \times 0.8 + 1.24 \times 0.6) = 22.2 \text{ V} \end{aligned}$$

$$V_2 = 400 - 22.2 = 377.8 \text{ V}$$

Problem 2:

A 100 KVA, transformer has an iron loss of 1KW and a Cu loss on normal output current of 1.5 KW. Calculate the KVA loading at which the efficiency is maximum and its efficiency at this loading (a) at unity p.f (b) at 0.8 p.f. lagging

Solution: Load KVA corresponding to maximum efficiency = full-load KVA

ironloss F.L.Cu loss

$$I = 100 \times 1.5 = 82.3 \text{ kVA}$$

(a) Total loss = 2 KW

$$x * \text{full load kVA} * p.f \times 100; \quad (x * \text{full load kVA} * p.f.) \times W_{cu} \times W_i$$

where x = ratio of actual to full load KVA ; $x = 1$;

$$= 82.3 * 1 = 97.63 \% \quad (82.3 * 1) \times 2$$

(b) At 0.8 p.f lagging

$$\eta = 82.3 * 0.8 = 97.05 \% \quad (82.3 * 0.8) \times 2$$