



Find solutions for your homework

Search

home / study / engineering / mechanical engineering / mechanical engineering questions and answers / 8-5. air pressure in the cylinder is increas...

Question: 8-5. Air pressure in the cylinder is increased by exerting forces...

(3 bookmarks)

Post a question

Answers from our experts for your toughest homework questions

Enter question

Continue to post

16 questions remaining

8-5. Air pressure in the cylinder is increased by exerting forces $P = 2 \text{ kN}$ on the two pistons, each having a radius of 45 mm. If the cylinder has a wall thickness of 2 mm, determine the state of stress in the wall of the cylinder.

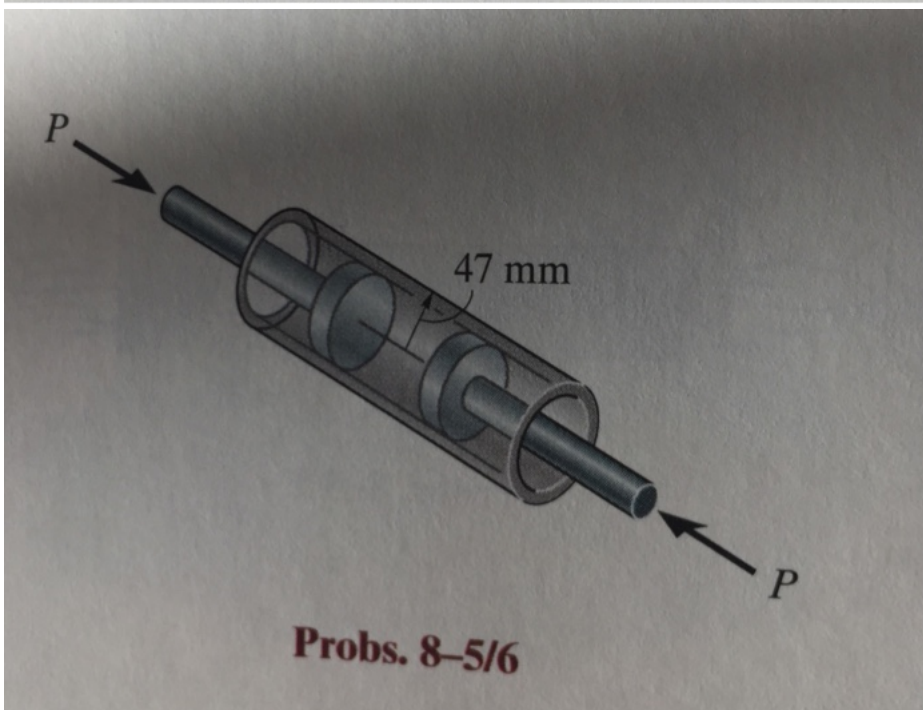

Show transcribed image text



Snap a photo from your phone to post a question

We'll send you a one-time download link

888-888-8888

Text me

By providing your phone number, you agree to receive a one-time automated text message with a link to get the app. Standard messaging rates may apply.

My Textbook Solutions



Vector
Mechanics...
12th Edition



University
Physics
14th Edition



Marketing
Channels
8th Edition

[View all solutions](#)

Expert Answer



Henry Miller answered this
1,149 answers

Was this answer helpful?





$$= \pi \left(45 \text{ mm} \times 10^{-3} \frac{\text{m}}{\text{mm}} \right)^2$$

$$= 0.006362 \text{ m}^2$$

Calculate the pressure inside the cylinder using the following relation:

$$p = \frac{P}{A}$$

$$= \frac{\left(2 \text{ kN} \times 10^3 \frac{\text{N}}{\text{kN}} \right)}{0.006362}$$

$$= 314366.55 \text{ Pa}$$

Calculate the circumferential stress using the following relation:

$$\sigma_c = \frac{pr}{t}$$

$$= \frac{(314366.55)(45)}{2}$$

$$= 7073247.41 \text{ Pa}$$

$$= 7.073 \text{ MPa}$$

As the pressure developed inside the cylinder is supported by the two piston surfaces in the longitudinal direction. So, there will be no longitudinal stress acting on the walls of the cylinder in the longitudinal direction.

Hence, the longitudinal stress is zero.

$$\sigma_{long} = 0$$

Comment >

Practice with similar questions

Q: Q. No. 1: Figuro-I shows a cylinder subjected to air pressure. Air pressure in the cylinder is increased by exerting forces P=2 kN on the two pistons, each having a radius of 45 mm. If the cylinder has a wall thickness of 2 mm, determine the state of stress in the wall of the cylinder.

A: [See answer](#)

Q: Figure 6. Problem No. 6 (Figure 6) Air pressure in the cylinder is increased by exerting forces P = 2 kN on the two pistons, each having a radius of 45 mm. If the cylinder has a wall thickness of 2 mm, determine the state of stress in the wall of the cylinder.

A: [See answer](#) 100% (3 ratings)

[Show more](#) ▾

Up next for you in Mechanical Engineering

12-87. The catapult is used to launch a ball such that it strikes the wall of the

12-87. The catapult is used to launch a ball such that it strikes the wall of the building at the maximum height of its trajectory. If it takes 1.5 s to travel from A to B, determine the velocity v_A at which it was launched, the angle of release θ , and the height h .



[See answer](#)

[See more questions for subjects you study](#)



The member has a rectangular cross-sectional area of width 0.5 in. and thickness 1 in. Determine the normal stress at point A and B. Determine the shear stress at point A and B.

A: [See step-by-step answer](#) 100% (31 ratings)

Q: Air pressure in the cylinder is increased by exerting forces $P = 3 \text{ kN}$ on the two pistons, each having a radius of 45 mm. The cylinder is shown in the figure below. If the cylinder has a wall thickness of 2 Mm, determine the circumferential stress in the wall of the cylinder. Express your answer to three significant figures and include appropriate units.

A: [See answer](#) 100% (39 ratings)

[Show more](#) 

COMPANY 

LEGAL & POLICIES 

CHEGG PRODUCTS AND SERVICES 

CHEGG NETWORK 

CUSTOMER SERVICE 



© 2003-2021 Chegg Inc. All rights reserved.