

SOLUTIONS

1, 6

$$s = \frac{a + b + c}{2}$$

$$s = \frac{13 + 20 + 21}{2}$$

$$s = 27$$

$$A_a = \frac{2}{b + c} \sqrt{bcs(s - a)}$$

$$A_a = \frac{2}{20 + 21} \sqrt{20(21)(27)(27 - 13)}$$

$A_a = 19.44 \text{ cm}$

Alternate solution:

Solve for the angle A.

$$\cos \angle A = \frac{20^2 + 21^2 - 13^2}{2(20)(21)}$$

$$\angle A = 36.87^\circ$$

$$\alpha = \frac{1}{2} \angle A = \frac{1}{2} 36.87^\circ$$

$$\alpha = 18.435^\circ$$

$$\cos \beta = \frac{13^2 + 21^2 - 20^2}{2(13)(21)}$$

$$\beta = 67.38^\circ$$

$$\theta = 180^\circ - 67.38^\circ - 18.435^\circ$$

$$\theta = 94.185^\circ$$

$$\frac{21}{\sin 94.185^\circ} = \frac{A_a}{\sin 67.38^\circ}$$

$$A_a = 19.44 \text{ cm}$$

2, 7

$a = 18 \text{ cm}$; $b = 10 \text{ cm}$; $d_1 = 17.5 \text{ cm}$

$$\cos \theta = \frac{a^2 + b^2 - d_1^2}{2ab}$$

$$\cos \theta = \frac{18^2 + 10^2 - 17.5^2}{2(18)(10)}$$

$$\cos \theta = 0.3270833333333333$$

$$\theta = 70.91^\circ$$

$$\alpha = 180^\circ - \theta$$

$$\alpha = 180^\circ - 70.91^\circ$$

$$\alpha = 109.09^\circ$$

$$d_2 = \sqrt{a^2 + b^2 - 2ab \cos \alpha}$$

$$d_2 = \sqrt{18^2 + 10^2 - 2(18)(10) \cos 109.09^\circ}$$

$$d_2 = 23.28 \text{ cm}$$

CMPLX COSINE LAW

$$d_2 = |18 - 10 \angle 109.09^\circ|$$

$$d_2 = 23.276 \text{ cm}$$

3, 8

$$A = \frac{\sqrt{(s - a)(s - b)(s - c)(s - d) - abcd \cos^2 \theta}}{s}$$

$$s = \frac{a + b + c + d}{2}$$

$$s = \frac{12 + 20 + 8 + 17}{2}$$

$$s = 28.5$$

$$\theta = \frac{1}{2} 225^\circ = 112.5^\circ$$

$$A = \frac{\sqrt{(28.5 - 12)(28.5 - 20)(28.5 - 8)(28.5 - 17) - (12)(20)(8)(17) \cos^2 112.5^\circ}}{28.5}$$

$$A = 168.18 \text{ m}^2$$

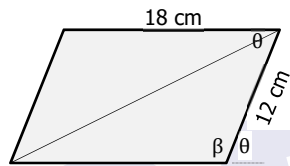
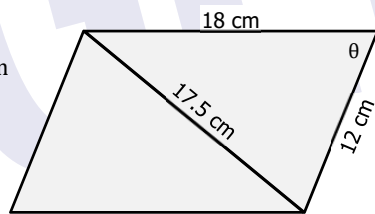
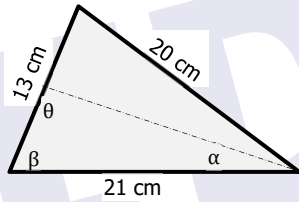

4, 9

$$R = \sqrt{3^2 + 6^2 + 2^2}$$

$$R = 7$$

$$\cos \theta_x = \frac{3}{7}$$

$$\theta_x = 64.62^\circ$$

Unit vector,
 $U_A = \cos \theta_x i + \cos \theta_y j + \cos \theta_z k$

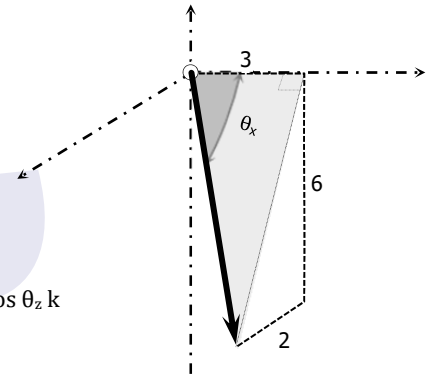

5, 10

$$a_1 = 30$$

$$a_2 = 32$$

$$d = 32 - 30 = 2$$

$$S_n = \frac{n}{2} [2a_1 + (n - 1)d]$$

$$S_{10} = \frac{10}{2} [2(30) + (10 - 1)(2)]$$

$$S_{10} = 390$$

$$S_T = 390 + 10(50)$$

$$S_T = 890$$

6, 1

At most one means it may be none or exactly one.

$$P = P_0 + P_1$$

$$P_0 = (1 - 0.34)(1 - 0.34)$$

$$P_0 = 0.4356$$

$$P_1 = 0.34(1 - 0.34) + (1 - 0.34)(0.34)$$

$$P_1 = 0.45$$

$$P = 0.4356 + 0.4488$$

$$P = 0.8844$$

$$\text{Or } P = 1 - 0.34^2 = 0.8844$$

7, 2

$$F_n = \frac{D[(1 + i)^n - 1]}{i}$$

$$F_{10} = F_5(1 + i)^5$$

$$500,000 = F_5(1 + 0.14)^5$$

$$F_5 = 259,684.33$$

$$F_5 = \frac{D[(1 + i)^n - 1]}{i}$$

$$259,684.33 = \frac{D[(1 + 0.14)^5 - 1]}{0.14}$$

$$D = \mathbf{P39,285.97}$$

8, 3

$$h = 24 \tan 20^\circ$$

$$h = 8.735 \text{ m}$$

$$AC = 8.735 \cot 30^\circ$$

$$AC = 15.129$$

$$BC^2 = 24^2 - 15.129^2$$

$$BC = \mathbf{18.631 \text{ m}}$$

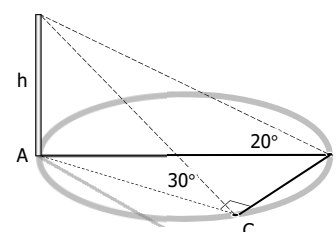
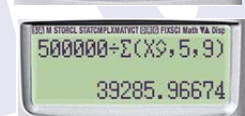
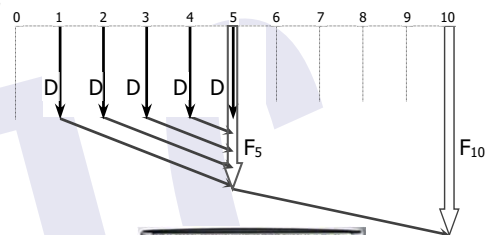

9, 4

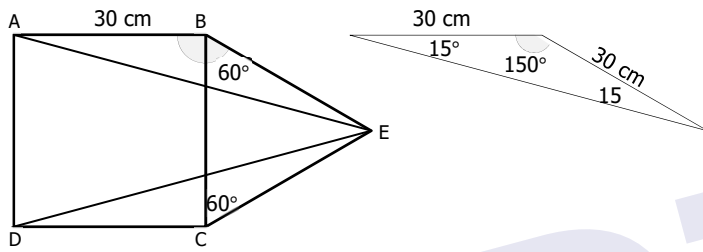

Angle AED = $60^\circ - 2(15^\circ)$
 Angle AED = 30°

10, 5

Point of intersection is located at point where $y'' = 0$
 $7y' = 12x - 3x^2$
 $7y'' = 12 - 6x = 0$
 $x = 2$

$$y = \frac{6(2)^2 - 2^3 + 5}{7}$$

$$y = 3$$

Point of inflection is at point **(2, 3)**

11, 16

For a conic section with equation:
 $Ax^2 + Bxy + Cy^2 + Dx + Ey + F = 0$

If A and C are EQUAL, the curve is a CIRCLE

If A and C are not EQUAL and with THE SAME SIGN, the curve is an ELLIPSE

If A and C are with DIFFERENT SIGNS, the curve is a HYPERBOLA

If A or C is zero, the curve is a PARABOLA

$7x^2 + 16y^2 - 16xy - 60x + 96y + 156 = 0$ is an **ellipse**

12, 17

Slope at any point on the curve is y' .

Differentiate both sides:

$$\frac{d}{dx}x^2 = \frac{d}{dx}(16y)$$

$$2x = 16\frac{dy}{dx}$$

$$y' = 2x/16$$

$$y' = x/8$$

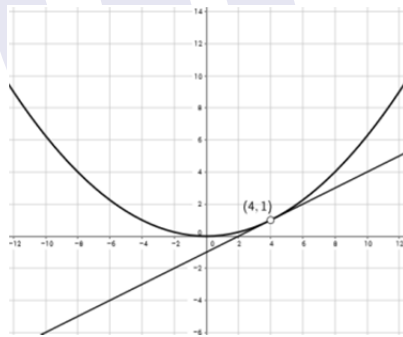

At point (4, 1)

$$y' = 4/8$$

$$y' = 1/2$$

$$y - y_1 = m(x - x_1)$$

$$y - 1 = (1/2)(x - 4)$$

$$2y - 2 = x - 4$$

$$2y + 2 = x$$

$$x = 2y + 2$$

13, 18

$$\sqrt{(x-1)^2 + (2-8)^2 + (4-3)^2} = 7.28$$

$$(x-1)^2 + (2-8)^2 + (4-3)^2 = 7.28^2$$

$$x^2 - 2x + 1 + 36 + 1 = 53$$

$$x^2 - 2x - 15 = 0$$

$$(x-5)(x+3) = 0$$

$$x = 5 \text{ or } x = -3$$

14, 19

$$A = x + 10$$

$$B = 2x + 10$$

$$C = 3x - 50$$

$$D = 2x - 10$$

$$A + B + C + D = 360^\circ$$

$$(x + 10) + (2x - 20) + (3x - 50) + (2x - 10) = 360$$

$$8x - 40 = 360$$

$$8x = 400$$

$$x = 50$$

$$A = 60$$

$$B = 110$$

$$C = 100$$

$$D = 90$$

15, 20

$$A = \pi r^2$$

$$201.06 = \pi r^2$$

$$r = 8.00 \text{ cm}$$

$$A_{\text{sec}} = \frac{1}{2} r^2 (2\theta)$$

$$\cos \theta = \frac{3}{8.00}$$

$$\theta = 67.976^\circ$$

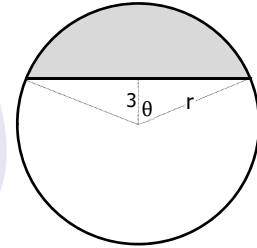

$$\theta = 67.976^\circ \times \pi/180^\circ$$

$$\theta = 1.186 \text{ rad}$$

$$A_{\text{sec}} = \frac{1}{2} 8.00^2 (2 \times 1.186)$$

$$A_{\text{sec}} = 75.904 \text{ cm}^2$$

$$A_{\text{tri}} = \frac{1}{2} r^2 \sin 2\theta$$

$$A_{\text{tri}} = \frac{1}{2} 8.00^2 \sin (2 \times 67.976^\circ)$$

$$A_{\text{tri}} = 22.248 \text{ cm}^2$$

$$A_{\text{seg}} = A_{\text{sec}} - A_{\text{tri}}$$

$$A_{\text{seg}} = 75.904 - 22.248$$

$$A_{\text{seg}} = \mathbf{53.656 \text{ cm}^2}$$

16, 11

$$x^2 = 20y$$

For a parabola with equation $y^2 = 4ax$ or $x^2 = 4ay$, the length of latus rectum is $4a$.

$$LR = 4a = \mathbf{20 \text{ units}}$$

17, 12

A plane parallel to $ax + by + cz = d_1$ and passes through (x_1, y_1, z_1) has an equation $ax + by + cz = d_2$, where $d_2 = ax_1 + by_1 + cz_1$

$$3x + 4y + z = d_2$$

$$d_2 = 3(2) + 4(1) + -3$$

$$d_2 = 7$$

18, 13

$$(x - y)^3 = x^3 - 3x^2y + 3xy^2 - y^3$$

19, 14

$$(3a^2 + 2a^2 + a - 2)(a + 4) = \mathbf{3a^4 + 14a^3 + 9a^2 + 2a - 8}$$

20, 15

Mean proportional

$$4/x = x/36$$

$$x^2 = 144$$

$$x = 12$$

21, 21

Total required man-hours = $72(100) = 7200$

$$80(40) + (80 - 30)x = 7200$$

$$x = \mathbf{80 \text{ days}}$$

22, 22

$$N = 100h + 10t + u$$

$$\frac{100h + 10t + u}{h + t + u} = 26$$

$$74h + -16t + -25u = 0$$

$$100h + 10t + u + 198 = 100u + 10t + h$$

$$99h - 99u = -198$$

Common difference of arithmetic progression:

$$d = t - h = u - t$$

$$h - 2t + u = 0$$



23, 23

By Pythagorean Theorem:

$$34^2 = a^2 + (a - 14)^2$$

$$1156 = a^2 + (a^2 - 28a + 196)$$

$$2a^2 - 28a - 960 = 0$$

$$a^2 - 14a - 480 = 0$$

$$(a + 16)(a - 30) = 0$$

$$a = -16$$

$$a = 30$$

$$a - 14 = 16$$

$$P = 30 + 16 + 34$$

$$P = 80 \text{ cm}$$

24, 24

$$S_1 = 6(17)$$

$$S_1 = 102$$

Let the larger number be x, then the smaller is x - 4

$$102 + x + x - 4 = (6 + 2)(19)$$

$$98 + 2x = 152$$

$$x = 27$$

25, 25

$$a_n = amr^{n-m}$$

$$160 = 20r^{6-3}$$

$$8 = r^3$$

$$r = 2$$

MODE 3:6, The common ratio is B in $y = AB^x$



26, 31

$$\frac{1}{2}(a + b) = 17$$

$$a + b = 34$$

$$ab = 8^2$$

$$ab = 64$$

$$a = 64/b$$

$$64/b + b = 34$$

$$b = 32$$

$$a = 2$$

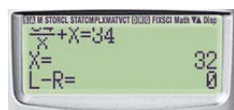

Relationship between GM, AM and HM.

$$GM^2 = AM \times HM$$

$$8^2 = 17HM$$

$$HM = 3.76$$

27, 32

$$3x - 3xi + 2y - 3yi = 5 - 9i$$

$$(3x + 2y) - (3x + 3y)i = 5 - 9i$$

Real Part: $3x + 2y = 5$

Imaginary Part: $3x + 3y = 9$

$$x = -1$$

$$y = 4$$

28, 33

$$A = i + 4j + 6k$$

$$B = 2i + 3j + 5k$$

$$A \times B = \begin{vmatrix} i & j & k \\ 1 & 4 & 6 \\ 2 & 3 & 5 \end{vmatrix}$$

$$A \times B = 20i + 12j + 3k - 8k - 18i - 5j$$

$$A \times B = 2i + 7j - 5k$$

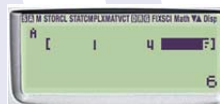

29, 34

$$N = (4 - 1)!4!$$

$$N = 3!4!$$

$$N = 144 \text{ ways}$$

30, 35

$$27 - x + x + 25 - x = 40$$

$$x = 12 \text{ students}$$

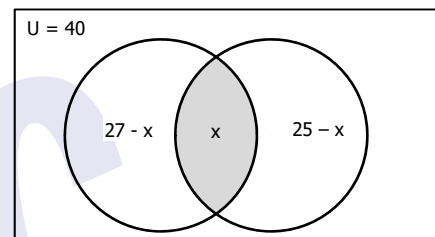

31, 26

$$R = \frac{abc}{4A}$$

$$s = \frac{a+b+c}{2}$$

$$s = \frac{40 + 50 + 60}{2}$$

$$s = 75$$

$$A = \sqrt{75(75 - 40)(75 - 50)(75 - 60)}$$

$$A = 992.16 \text{ cm}^2$$

$$R = \frac{40(50)(60)}{4(992.16)}$$

$$R = 30.24 \text{ cm}$$

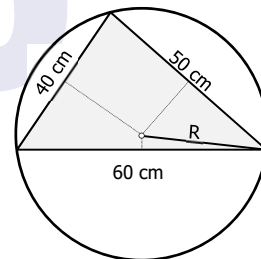

32, 27

$$8x = 20(12)$$

$$x = 30$$

$$\text{Diameter, } D = 38 \text{ inches}$$

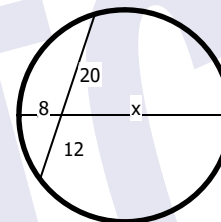

33, 28

$$A_L = \pi rL$$

$$40\pi = \pi 4L$$

$$L = 10 \text{ inches}$$

34, 29

$$V = \frac{2}{3}\pi r^2 h$$

$$h = r - r \cos \frac{1}{2}50^\circ$$

$$h = 0.093692r$$

$$400 = \frac{2}{3}\pi r^2 (0.093692r)^2$$

$$400 = 0.1962280659334r^3$$

$$r = 12.68 \text{ cm}$$

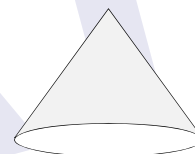

35, 30

$$V = \frac{\pi h}{3}(R^2 + r^2 + Rr)$$

$$980\pi = \frac{15\pi}{3}(10^2 + r^2 + 10r)$$

$$196 = 100 + r^2 + 10r$$

$$r^2 + 10r - 96 = 0$$

$$(r - 6)(r + 16) = 0$$

$$r = 6 \text{ or } r = -16$$

36, 36

$$P = \frac{D[(1+i)^n - 1]}{i(1+i)^n}$$

$$P = \frac{40000[(1+0.08)^5 - 1]}{0.08(1+0.08)^5}$$

$$P = 159,708.40$$

$$BCR = \frac{P}{FC}$$

$$BCR = \frac{159,708.40}{100,000}$$

$$BCR = 1.597$$

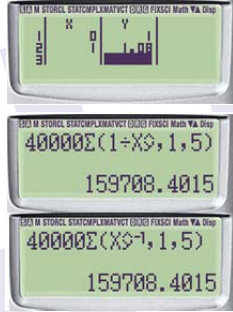

37, 37

$$FC = 20,000$$

$$SV = 1,000$$

$$i = 0.03$$

$$n = 10$$

$$m = 6$$

$$d = \frac{FC - SV}{(1+i)^n - 1} i$$

$$d = \frac{20000 - 1000}{(1+0.03)^{10} - 1} 0.03$$

$$d = 1657.38$$

$$D_m = \frac{d[(1+i)^m - 1]}{i}$$

$$D_6 = \frac{1657.38[(1+0.03)^6 - 1]}{0.03}$$

$$D_6 = 10720.61$$

$$BV_6 = 20,000 - 10720.61$$

$$BV_6 = \mathbf{P9,279.39}$$

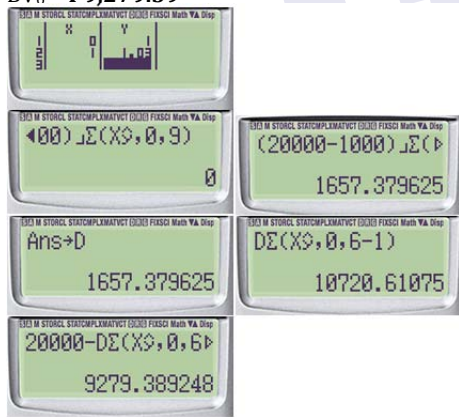

38, 38

$$CC = FC + \frac{OM}{i} + \frac{FC - SV}{(1+i)^n - 1}$$

$$CC = 75 + \frac{0.06}{0.06} + \frac{FC - SV}{(1+0.06)^{30} - 1}$$

$$CC = \mathbf{P133.43 M}$$

39, 39

$$F = P(1+i/m)^{mn}$$

$$4P = P(1+0.07/2)^{2n}$$

$$n = \mathbf{20.1488 \text{ years}}$$

MODE 3:6



40, 40

$$R = \sqrt{\frac{D^2 + E^2 - 4AF}{4A^2}}$$

$$R = \sqrt{\frac{4^2 + 6^2 - 4(1)(-51)}{4(1)^2}}$$

$$R = 8$$

$$LC = 2\sqrt{R^2 - d^2}$$

$$LC = \mathbf{12.5 \text{ units}}$$

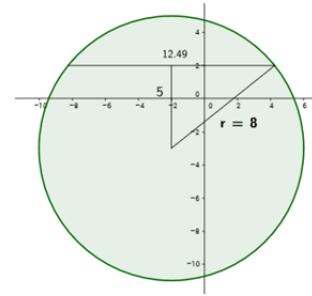

41, 41

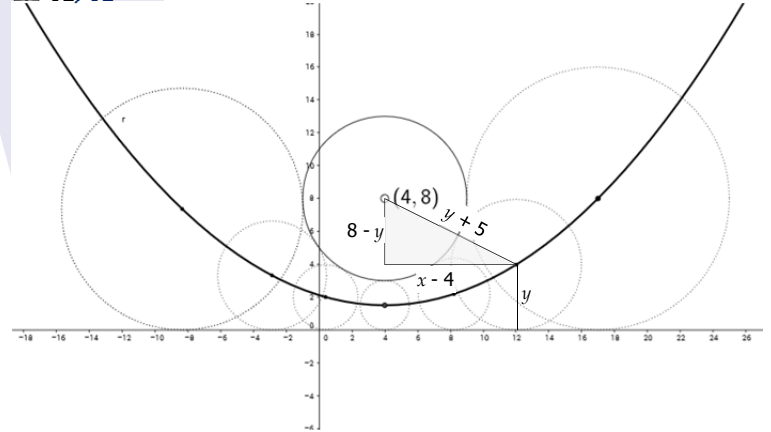

$$(y+5)^2 = (8-y)^2 + (x-4)^2$$

$$y^2 + 10y + 25 = 64 - 16y + y^2 + x^2 - 8x + 16$$

$$x^2 - 8x - 26y + 55 = 0$$

42, 42

$$r = \sqrt{x^2 + y^2}$$

$$\sin \theta = \frac{y}{r}$$

$$\cos \theta = \frac{x}{r}$$

$$r = \frac{1 - \sin \theta}{1 - \sin \theta}$$

$$r(1 - y/r) = 4$$

$$r - y = 4$$

$$r = 4 + y$$

$$\sqrt{x^2 + y^2} = (4 + y)$$

$$x^2 + y^2 = (4 + y)^2$$

$$x^2 + y^2 = 16 + 8y + y^2$$

$$x^2 - 8y - 16 = 0$$

$$LR = \mathbf{8 \text{ units}}$$

For $r = k/(1 \pm \sin \theta)$
 $LR = 2k$

$$2k = 2(4) = \mathbf{8 \text{ units}}$$

43, 43

$$xy = 16$$

$$x^2 = 16$$

$$x = 4$$

$$a = \mathbf{4\sqrt{2}}$$

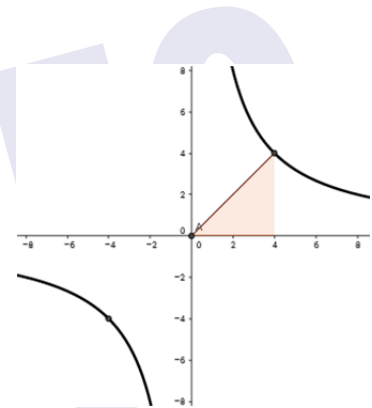

44, 44

$$\cos \theta = 0.8660$$

$$\theta = 30.00^\circ \text{ rad}$$

$$\tan 30.00^\circ = 2/3$$

45, 45

$$R_A = \sqrt{1^2 + 2^2 + 7^2} = 14.8$$

$$R_B = \sqrt{8^2 + 6^2 + 12^2} = 15.6 > 15 \text{ units}$$

$$R_C = \sqrt{10^2 + 9^2 + 4^2} = 14$$

$$R_D = \sqrt{4^2 + 8^2 + 7^2} = 11.4$$

Letter B.

46, 46

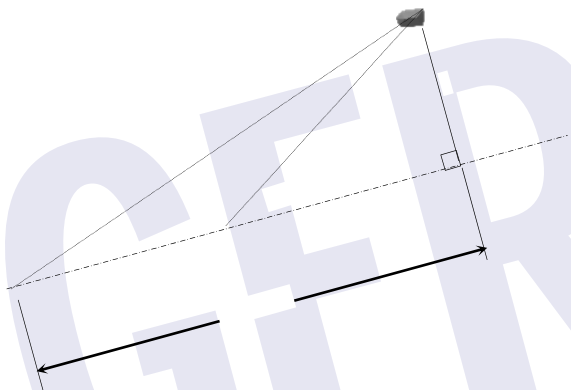

$$4.8 + x/\tan 55^\circ = x/\tan 31^\circ$$

$$x = 5.0 \text{ m}$$

47, 47

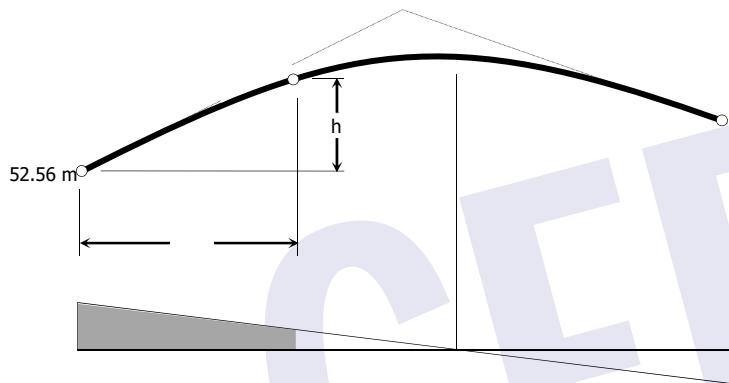

$$h = 53.23 - 52.56$$

$$h = 0.67 \text{ m}$$

$$h = \frac{1}{2}(g_1 + g_3)b$$

$$0.67 = \frac{1}{2}(0.02 + g_3)(54)$$

$$g_3 = 0.0048$$

Equation of grade:



Location of the summit

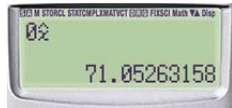

Elevation of the summit

$$E_{\text{sum}} = 52.56 + \frac{1}{2} 71.05(0.02) = 53.27 \text{ m}$$

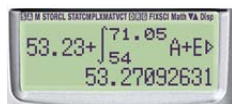

48, 48

$$R = 1145.916/5$$

$$R = 229.183 \text{ m}$$

$$L = 0.036(90^3)/229.183$$

$$L = 114.51 \text{ m}$$

49, 49

$$L_c = \frac{0.0215v^3}{Ra_c}$$

$$L_c = \frac{0.0215(100)^3}{340(0.79)}$$

$$L_c = 80.04 \text{ m}$$

50, 50

Input in mode 3:1(1-Var)

X as the differences in elevation and FREQ as the reciprocal of respective distances.



$$\text{Elevation of B} = 825.58 - 0.8256$$

$$\text{Elevation of B} = 824.7544 \text{ m}$$

51, 56

$$g_1 = -1.5\%; g_2 = 3.5\%$$

$$S = 2(89)$$

$$S = 178 \text{ m}$$

Assume $S < L$

$$L = \frac{AS^2}{120 + 3.5S}$$

$$L = \frac{5(178)^2}{120 + 3.5(178)}$$

$$L = 213.22 \text{ m} > S, \text{ assumption is correct}$$

$$L = \frac{Av^2}{395}$$

$$213.22 = \frac{5v^2}{395}$$

$$v = 129.786 \text{ kph}$$

52, 57

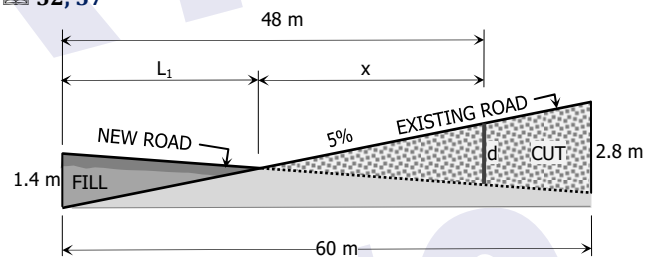

By ratio and proportion:

$$\frac{L_1}{1.4} = \frac{60 - L_1}{2.8}; L_1 = 20 \text{ m}$$

$$x = 48 - 20 = 28 \text{ m}$$

$$\frac{d}{28} = \frac{1.4}{20}; d = 1.96 \text{ m}$$

$$C = 14 + 2(1.96 \times 2)$$

$$C = 21.84$$

$$A = \frac{14 + 21.84}{2} \times 1.96$$

$$A = 35.123 \text{ m}^2 \text{ (letter C)}$$

Area (formula)

$$A = d(b + md)$$

$$A = md + bd^2$$

Where: d = depth
b = road width
m = side slope

$$A = 1.96(14 + 2 \times 1.96)$$

$$A = 35.123 \text{ m}^2$$

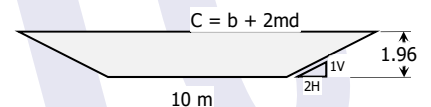

53, 59

$$E = \pm 0.6745 \sqrt{\frac{\sum v^2}{n(n-1)}}$$

$$x_m = \frac{856.42 + 856.69 + 856.12}{3}$$

$$x_m = 856.41$$

$v = x_m - x$; $x = \text{sample}$

$$\sum v^2 = (856.41 - 856.42)^2 + (856.41 - 856.69)^2 + (856.41 - 856.12)^2$$

$$\sum v^2 = (-0.01)^2 + (-0.28)^2 + (0.29)^2$$

$$\sum v^2 = 0.163$$

$$E = \pm 0.6745 \sqrt{\frac{0.163}{3(3-1)}}$$

$$E = \pm 0.111$$

Alternative Solution:
MODE 3:1

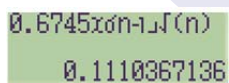

54, 59

Since this is just a linear equation, use MODE 3:2 in calculator
Mode 3:2 has a linear regression function in the form $y = A + Bx$
When $x = 0$, $y = 150,900$
When $x = 5$ (2006 - 2001); $y = 222,000$



Press [AC]

Then the coefficient of x (slope) is B [Shift] [1][7][2] [=]



Then the constant term (y -intercept) is A [Shift] [1][7][1] [=]



Then the equation is $y = 14,220x + 150,900$ (B)

55, 60

$S = 0.08 \text{ m}$
 $D = 100 \text{ m}$
 $\tan \theta = 0.08/100$

$\theta = 0.00080 \text{ rad}$
 $\theta = 0.04584^\circ$
 $\theta = 165''$
Sensitivity = 165/6
Sensitivity = 27.5

56, 51

$A_1 = 36 \text{ m}^2$

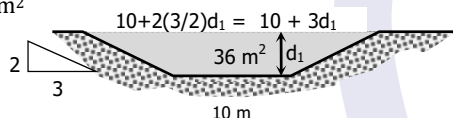

$36 = d[(10 + 3d) + 10]/2$
 $d_1 = C_1 = 2.592$
 $D_1 = 10 + 3d_1 = 17.776$

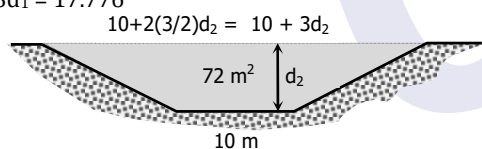

$72 = d[(10 + 3d) + 10]/2$
 $d = C_2 = 4.355$
 $D_2 = 10 + 3d_2 = 23.065$

$V_E = (36 + 72)(65/2) = 3510$
 $V_{cp} = (17.776 - 23.065)(2.592 - 4.355)(65/12)$
 $V_{cp} = 50.508$
 $V_p = 3510 - 50.508$
 $V_p = 3459.492 \text{ m}^2$

57, 52

Original price = P
Due to inflation, $P_1 = 1.05P$
Final price = $1.05P - 0.10(1.05P) = 0.945P$

58, 53

Expectation = $2(1/3) + 3(1/2) + 11(1/6)$
Expectation = 4.00

59, 54

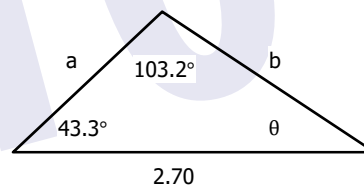

By sine law:

$$\frac{a}{\sin(33.5^\circ)} = \frac{2.70}{\sin(103.2^\circ)} = \frac{b}{\sin(43.3^\circ)}$$

$a = 1.5307$
 $b = 1.9020$

60, 55

$335 = 125 + 0.20C$
 $C = 1050$

61, 61

$C = 8x^2 - 176x + 1800$
 $dC/dx = 16x - 176 = 0$
 $x = 11 \text{ units}$

62, 62

$h = -16t^2 + 12t + 200 = 0$

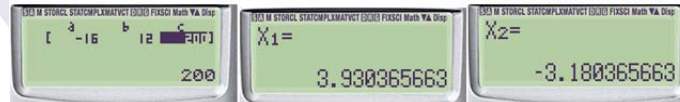

63, 63

$\frac{5}{x+1} + 2 < 0$

$\frac{5 + 2(x+1)}{(7+2x)(x+1)} < 0$
 $\frac{x+1}{(7+2x)(x+1)} < 0$

For $N/D < 0$,
if $N < 0$ then $D > 0$
If $N > 0$, then $D < 0$

Let $N > 0$
 $7 + 2x > 0$
 $x > -7/2 > -3.5$

try $x = -3.4$
 $D = x + 1 = -2.4 < 0$, OK

Try $D < 0$
 $x + 1 < 0$, $x < -1$
try $x = -2$
 $N = 7 + 2x = 7 + 2(-2) = 3 > 0$ OK

Then, the solution is $x > -7/2$ or $x < -1$
 $(-7/2, -1)$

64, 64

$S_3 = 2 + 1.25 + 1$
 $S_3 = 4.25$
 $S_3 = 4 \frac{1}{4}$



65, 65

d = 1
n = 20

a₂₀ = 3 + (20 - 1)(1)
a₂₀ = 22

S = $\frac{20}{2}(3 + 22)$
S = **250 rolls**

MODE 3:2 for ARITHMETIC sequence



66, 66

S = $\frac{a_1(1 - r^n)}{1 - r}$

S = $\frac{800,000(1 - 0.75^6)}{1 - 0.75}$

S = **\$2,630,468.75**

MODE 3:6 for Geometric Sequence

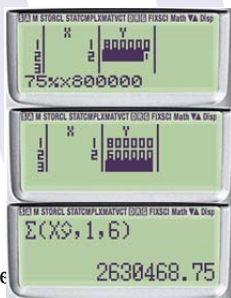

67, 67

y = y₀e^{0.043t}
y = 83e^{0.043(5)}
y = 103

68, 68

log₂x + log₂(x - 1) = 1
log₂ x(x - 1) = 1

x(x - 1) = 2¹
x² - x - 2 = 0
(x - 2)(x + 1) = 0

x = 2 or x = -1
B. 2

69, 69

I = k/R
k = IR
40(270) = 150I
I = **72 amperes**

70, 70

P - 0.08P = 2162
P = **\$2350**

71, 72

Urban Roads are roads where speed limits are 60 kph or less.
Rural Roads are roads where speed limits are 60 kph or more.

72, 71

Parking lines and Markings is NOT classified as transverse line

Transverse lines may be classified into the following types:

- Stop Lines;**
- Give Way lines;**
- Pedestrian Crossing Markings;** and,
- Roundabout Holding Lines.**

73, 74

Messages are white in color. **Letters or numerals used on roads in urban areas shall be at least 2.5 m.** On high speed highways, they must be at least 5m.

74, 74

Pavement arrows are used for lane use control. White in color, they are generally 5 meters in length on urban roads and **7.5 meters** on high-speed roads

75, 75

Reaction Distance - The distance traveled while the driver perceives a hazard, decides to take action, and then acts by starting to apply the brakes to start slowing down.

Braking Distance - The distance required for the vehicle to slow down and stop.

END

SET A

- 1 C 11 C 21 D 31 C 41 C 51 C 61 B 71 B
- 2 A 12 A 22 B 32 D 42 C 52 D 62 B 72 D
- 3 D 13 B 23 A 33 B 43 B 53 C 63 A 73 C
- 4 B 14 C 24 B 34 D 44 C 54 B 64 D 74 C
- 5 A 15 A 25 A 35 D 45 B 55 B 65 C 75 A

- 6 D 16 C 26 D 36 C 46 C 56 C 66 A
- 7 A 17 D 27 C 37 A 47 D 57 D 67 D
- 8 C 18 A 28 A 38 A 48 A 58 B 68 B
- 9 C 19 B 29 B 39 D 49 D 59 B 69 D
- 10 A 20 A 30 B 40 C 50 B 60 D 70 C

SET B

- 1 D 11 C 21 D 31 D 41 C 51 C 61 B 71 D
- 2 A 12 D 22 B 32 C 42 C 52 D 62 B 72 B
- 3 C 13 A 23 A 33 A 43 B 53 B 63 A 73 C
- 4 C 14 B 24 B 34 B 44 C 54 B 64 D 74 C
- 5 A 15 A 25 A 35 B 45 B 55 D 65 C 75 A

- 6 C 16 C 26 C 36 C 46 C 56 C 66 A
- 7 A 17 A 27 D 37 A 47 D 57 D 67 D
- 8 D 18 B 28 B 38 A 48 A 58 C 68 B
- 9 B 19 C 29 D 39 D 49 D 59 B 69 D
- 10 A 20 A 30 D 40 C 50 B 60 B 70 C