

# Equilibrium of Force System

The body is said to be in equilibrium if the resultant of all forces acting on it is zero. There are two major types of static equilibrium, namely, translational equilibrium and rotational equilibrium.

## Formulas

Concurrent force system

$$\Sigma F_x = 0$$

$$\Sigma F_y = 0$$

Parallel Force System

$$\Sigma F = 0$$

$$\Sigma M_O = 0$$

Non-Concurrent Non-Parallel Force System

$$\Sigma F_x = 0$$

$$\Sigma F_y = 0$$

$$\Sigma M_O = 0$$

## 1. Equilibrium of Concurrent Force System

In static, a body is said to be in equilibrium when the force system acting upon it has a zero resultant.

### Conditions of Static Equilibrium of Concurrent Forces

The sum of all forces in the x-direction or horizontal is zero.

$$\Sigma F_x = 0 \text{ or } \Sigma F_H = 0$$

The sum of all forces in the y-direction or vertical is zero.

$$\Sigma F_y = 0 \text{ or } \Sigma F_V = 0$$

### Important Points for Equilibrium Forces

- Two forces are in equilibrium if they are equal and oppositely directed.
- Three coplanar forces in equilibrium are concurrent.
- Three or more concurrent forces in equilibrium form a close polygon when connected in head-to-tail manner.

## Problem 308 | Equilibrium of Concurrent Force System

The cable and boom shown in [Fig. P-308](#) support a load of 600 lb. Determine the tensile force  $T$  in the cable and the compressive force  $C$  in the boom.

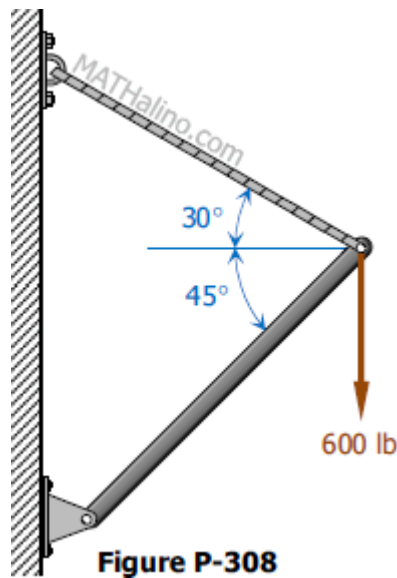

### Solution 308

$$\Sigma F_H = 0$$

$$C \cos 45^\circ = T \cos 30^\circ$$

$$C = 1.2247T$$

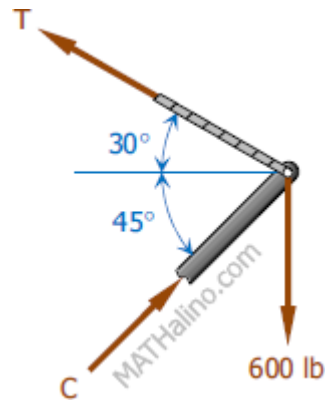

$$\Sigma F_V = 0$$

$$T \sin 30^\circ + C \cos 45^\circ = 600$$

$$T \sin 30^\circ + (1.2247T) \cos 45^\circ = 600$$

$$1.366T = 600$$

$$T = 439.24 \text{ lb} \quad \text{answer}$$

$$C = 1.2247(439.24)$$

$$C = 537.94 \text{ lb} \quad \text{answer}$$

### Another Solution (By Rotation of Axes)

$$\Sigma F'_y = 0$$

$$T \sin 75^\circ = 600 \sin 45^\circ$$

$$T = 439.23 \text{ lb} \quad (\text{ok!})$$

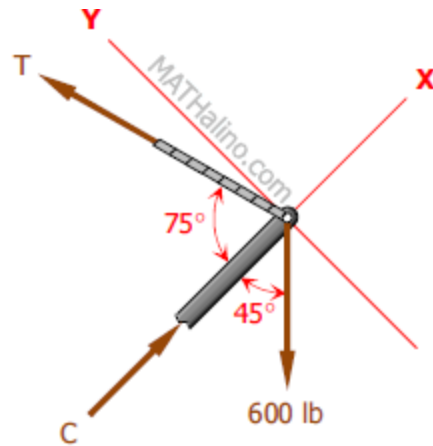

$$\Sigma F_x = 0$$

$$C = T \cos 75^\circ + 600 \cos 45^\circ$$

$$C = 439.23 \cos 75^\circ + 600 \cos 45^\circ$$

$$C = 537.94 \text{ lb} \quad (\text{ok!})$$

Another Solution (By Force Polygon)

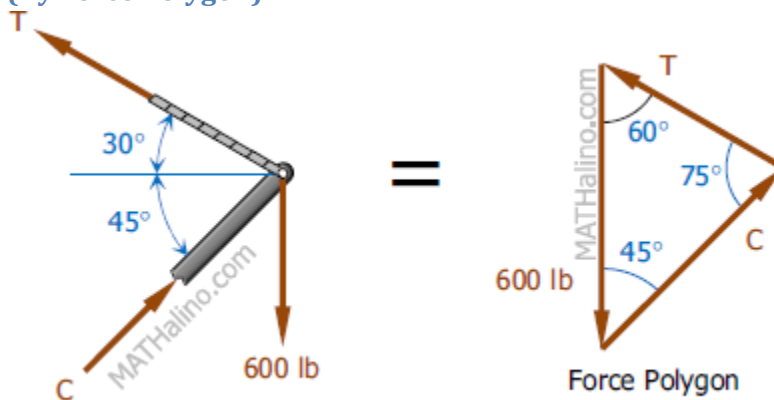

$$\frac{T}{\sin 45^\circ} = \frac{C}{\sin 60^\circ} = \frac{600}{\sin 75^\circ}$$

$$T = 439.23 \text{ lb} \quad (\text{ok!})$$

$$C = 537.94 \text{ lb}$$

(ok!)

## Problem 309 | Equilibrium of Concurrent Force System

A cylinder weighing 400 lb is held against a smooth incline by means of the weightless rod AB in [Fig. P-309](#). Determine the forces  $P$  and  $N$  exerted on the cylinder by the rod and the incline.

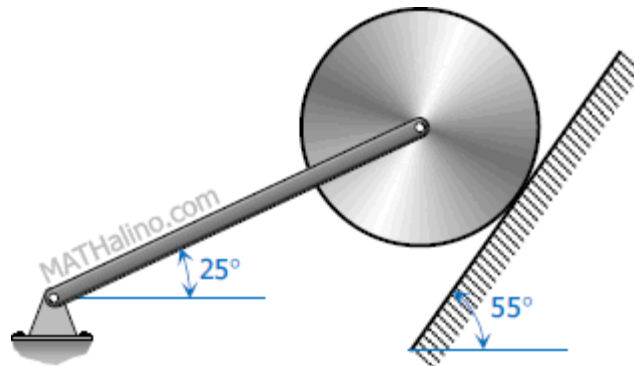

Figure P-309

### Solution 309

$$\Sigma F_H = 0$$

$$P \cos 25^\circ = N \sin 55^\circ$$

$$P = 0.9038N$$

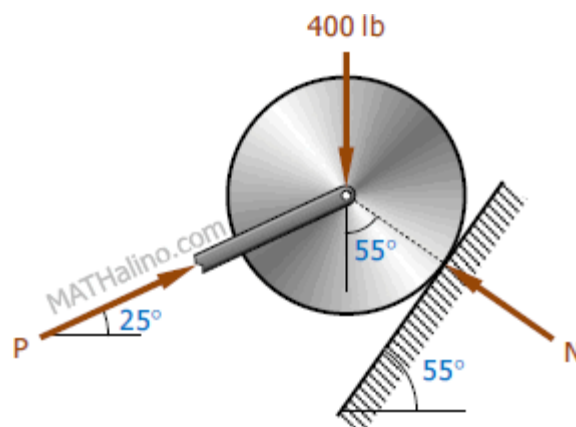

$$\Sigma F_V = 0$$

$$P \sin 25^\circ + N \cos 55^\circ = 400$$

$$(0.9038N) \sin 25^\circ + N \cos 55^\circ = 400$$

$$0.9556N = 400$$

$$N = 418.60 \text{ lb} \quad \textit{answer}$$

$$P = 0.9038(418.60)$$

$$P = 378.34 \text{ lb} \quad \textit{answer}$$

### Another Solution (By Rotation of Axes)

$$\Sigma F_x = 0$$

$$P \cos 30^\circ = 400 \sin 55^\circ$$

$$P = 378.35 \text{ lb} \quad \textit{(ok!)}$$

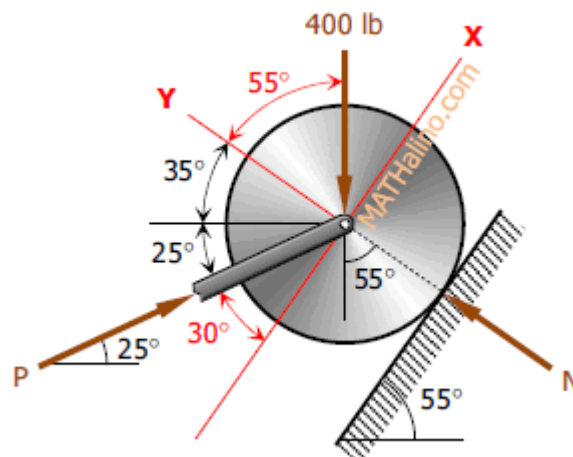

$$\Sigma F_y = 0$$

$$N = P \sin 30^\circ + 400 \cos 55^\circ$$

$$N = 378.35 \sin 30^\circ + 400 \cos 55^\circ$$

$$N = 418.60 \text{ lb} \quad (\text{ok!})$$

### Another Solution (By Force Polygon)

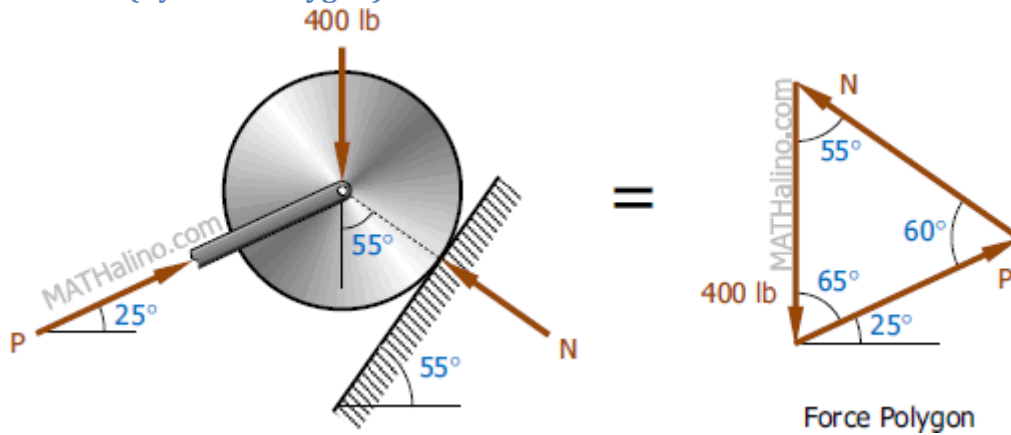

$$\frac{P}{\sin 55^\circ} = \frac{N}{\sin 65^\circ} = \frac{400}{\sin 60^\circ}$$

$$P = 378.35 \text{ lb} \quad (\text{ok!})$$

$$N = 418.60 \text{ lb} \quad (\text{ok!})$$

## Problem 310 - 311 | Equilibrium of Concurrent Force System

### Problem 310

A 300-lb box is held at rest on a smooth plane by a force  $P$  inclined at an angle  $\theta$  with the plane as shown in [Fig. P-310](#). If  $\theta = 45^\circ$ , determine the value of  $P$  and the normal pressure  $N$  exerted by the plane.

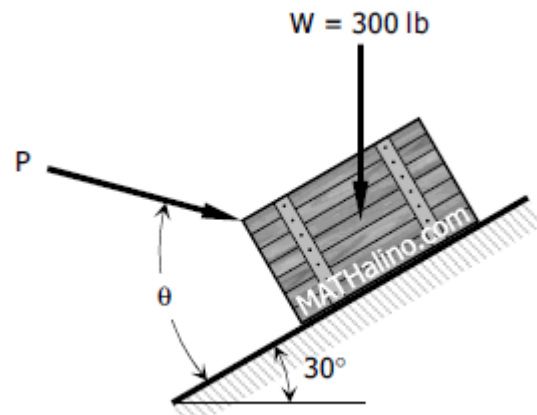

Figure P-310 and P-311

**Solution 310**

$$\Sigma F'_x = 0$$

$$P \cos \theta = W \sin 30^\circ$$

$$P \cos 45^\circ = 300 \sin 30^\circ$$

$$P = 212.13 \text{ lb} \quad \text{answer}$$

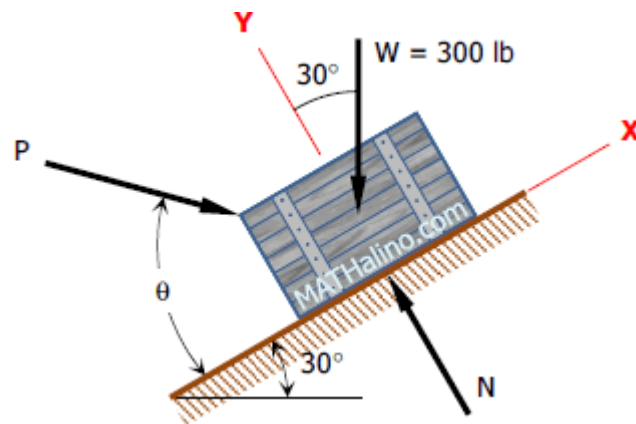

$$\Sigma F_y = 0$$

$$N = P \sin \theta + W \cos 30^\circ$$

$$N = 212.13 \sin 45^\circ + 300 \cos 30^\circ$$

$$N = 409.81 \text{ lb} \quad \text{answer}$$

### Problem 311

If the value of  $P$  in Fig. P-310 is 180 lb, determine the angle  $\theta$  at which it must be inclined with the smooth plane to hold 300-lb box in equilibrium.

### Solution 311

$$\Sigma F'_x = 0$$

$$P \cos \theta = W \sin 30^\circ$$

$$180 \cos \theta = 300 \sin 30^\circ$$

$$\cos \theta = \frac{5}{6}$$

$$\theta = 33.56^\circ \quad \text{answer}$$

## Problem 312 | Equilibrium of Concurrent Force System

Determine the magnitude of  $P$  and  $F$  necessary to keep the concurrent force system in Fig. P-312 in equilibrium.

### Solution 312

$$\Sigma F'_H = 0$$

$$F \cos 60^\circ + 200 \cos 45^\circ = 300 + P \cos 30^\circ$$

$$F = 317.16 + 1.7320P$$

$$\Sigma F'_V = 0$$

$$F \sin 60^\circ = 200 \sin 45^\circ + P \sin 30^\circ$$

$$(317.16 + 1.7320P) \sin 60^\circ = 200 \sin 45^\circ + P \sin 30^\circ$$

$$274.67 + 1.5P = 141.42 + 0.5P$$

$$P = -133.25 \text{ N} \quad \text{answer}$$

$$F = 317.16 + 1.7320(-133.25)$$

$$F = 86.37 \text{ N} \quad \text{answer}$$

## Problem 313 | Equilibrium of Concurrent Force System

Problem 313 | Equilibrium of Concurrent Force System  
 Figure P-313 represents the concurrent force system acting at a joint of a bridge truss. Determine the value of P and E to maintain equilibrium of the forces.

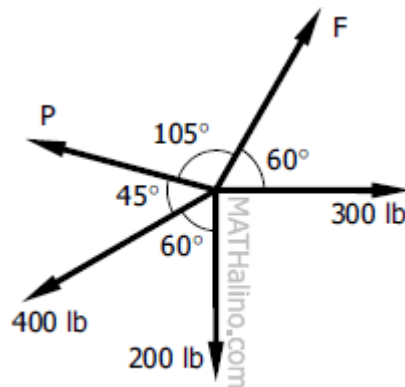

**Figure P-313**

### Solution 313

$$\Sigma F_x = 0$$

$$F \cos 60^\circ + 300 = P \cos 15^\circ + 400 \cos 30^\circ$$

$$F = 1.9318P + 92.82$$

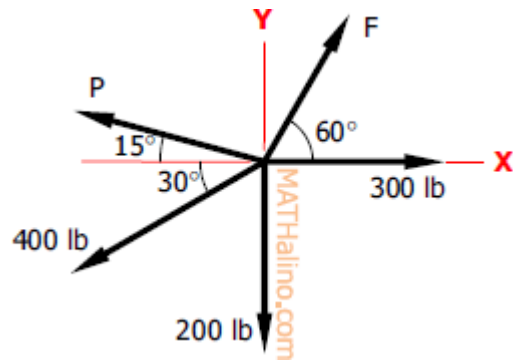

$$\Sigma F_y = 0$$

$$F \sin 60^\circ + P \sin 15^\circ = 200 + 400 \sin 30^\circ$$

$$(1.9318P + 92.82) \sin 60^\circ + P \sin 15^\circ = 200 + 400 \sin 30^\circ$$

$$1.6730P + 80.38 + 0.2588P = 200 + 200$$

$$1.9318P = 319.62$$

$$P = 165.45 \text{ lb} \quad \textit{answer}$$

$$F = 1.9318(165.45) + 92.82$$

$$F = 412.44 \text{ lb} \quad \textit{answer}$$

## Problem 314 | Equilibrium of Concurrent Force System

The five forces shown in Fig. P-314 are in equilibrium. Compute the values of P and F.

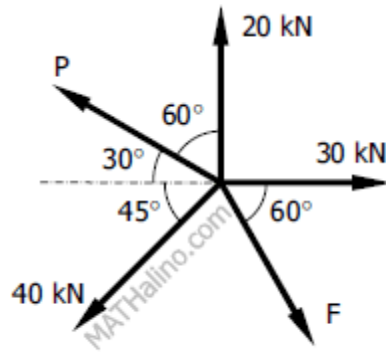

**Figure P-314**

**Solution 314**

$$\sum F'_y = 0$$

$$F \sin 30^\circ + 40 \cos 15^\circ = 30 \sin 30^\circ + 20 \sin 60^\circ$$

$$0.5F = -6.3165$$

$$F = -12.63 \text{ kN} \quad \text{answer}$$

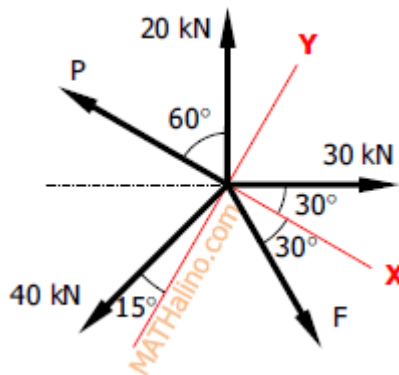

$$\sum F'_x = 0$$

$$P + 20 \cos 60^\circ + 40 \sin 15^\circ = 30 \cos 30^\circ + F \cos 30^\circ$$

$$P + 10 + 10.35 = 25.98 + (-12.63)(0.8660)$$

$$P = -5.31 \text{ kN} \quad \text{answer}$$

# Problem 315 | Equilibrium of Concurrent Force System

The 300-lb force and the 400-lb force shown in Fig. P-315 are to be held in equilibrium by a third force  $F$  acting at an unknown angle  $\theta$  with the horizontal. Determine the values of  $F$  and  $\theta$ .

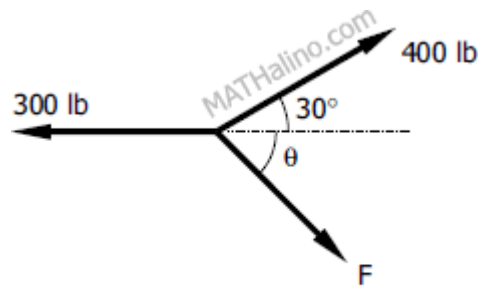

Figure P-315

## Solution 315

By Cosine Law

$$F^2 = 400^2 + 300^2 - 2(400)(300) \cos 30^\circ$$

$$F^2 = 42\,153.90 \text{ lb}$$

$$F = 205.31 \text{ lb} \quad \text{answer}$$

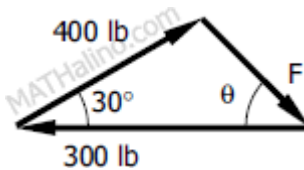

$$400^2 = 300^2 + F^2 - 300F \cos \theta$$

$$300F \cos \theta = 300^2 + F^2 - 400^2$$

$$300(205.31) \cos \theta = 300^2 + 42\,153.90 - 400^2$$

$$61\,593 \cos \theta = -27\,846.1$$

$$\cos\theta = -0.4520984527$$

$$\theta = 116.87^\circ \quad \text{answer}$$

The correct position of F would be as shown below.

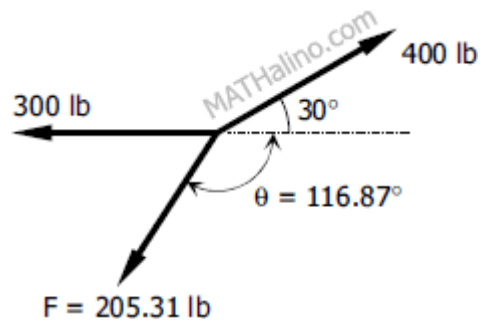

## Problem 316 | Equilibrium of Concurrent Force System

Determine the values of  $\alpha$  and  $\theta$  so that the forces shown in Fig. P-316 will be in equilibrium.

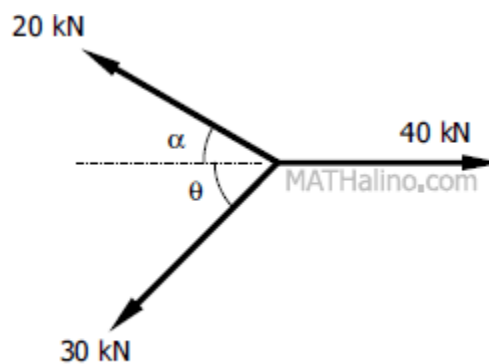

**Figure P-316**

### Solution 316

By Cosine Law

$$30^2 = 20^2 + 40^2 - 2(20)(40) \cos \alpha$$

$$2(20)(40) \cos \alpha = 20^2 + 40^2 - 30^2$$

$$1600 \cos \alpha = 1100$$

$$\cos \alpha = 0.6875$$

$$\alpha = 46.57^\circ \quad \text{answer}$$

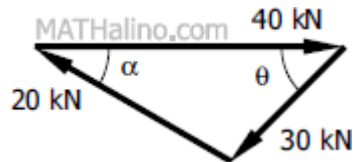

$$20^2 = 30^2 + 40^2 - 2(30)(40) \cos \theta$$

$$2(30)(40) \cos \theta = 30^2 + 40^2 - 20^2$$

$$2400 \cos \theta = 2100$$

$$\cos \theta = 0.875$$

$$\theta = 28.96^\circ \quad \text{answer}$$

## Problem 317 | Equilibrium of Concurrent Force System

The system of knotted cords shown in [Fig. P-317](#) support the indicated weights. Compute the tensile force in each cord.

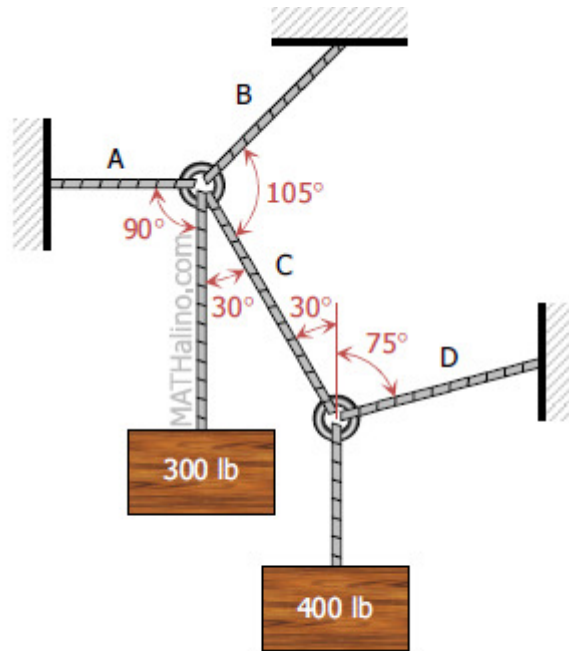

**Figure P-317**

**Solution 317**

From the knot containing 400-lb load

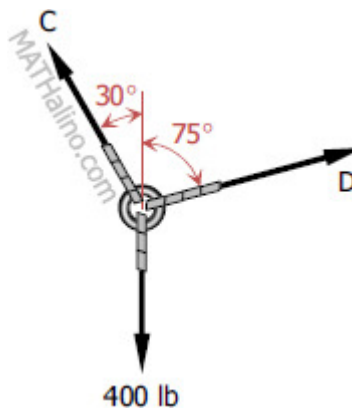

$$\Sigma F_H = 0$$

$$D \sin 75^\circ = C \sin 30^\circ$$

$$D = 0.5176C$$

$$\Sigma F_V = 0$$

$$D \cos 75^\circ + C \cos 30^\circ = 400$$

$$(0.5176C) \cos 75^\circ + C \cos 30^\circ = 400$$

$$C = 400 \text{ lb} \quad \text{answer}$$

$$D = 0.5176(400)$$

$$D = 207.06 \text{ lb} \quad \text{answer}$$

From the knot containing 300-lb load

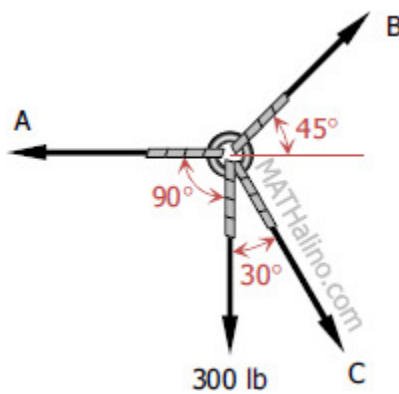

$$\Sigma F_V = 0$$

$$B \sin 45^\circ = 300 + C \cos 30^\circ$$

$$B \sin 45^\circ = 300 + 400 \cos 30^\circ$$

$$B = 914.16 \text{ lb} \quad \text{answer}$$

$$\Sigma F_H = 0$$

$$A = B \cos 45^\circ + C \sin 30^\circ$$

$$A = 914.16 \cos 45^\circ + 400 \sin 30^\circ$$

$$A = 846.41 \text{ lb} \quad \text{answer}$$

## Problem 318 | Equilibrium of Concurrent Force System

Three bars, hinged at A and D and pinned at B and C as shown in [Fig. P-318](#), form a four-link mechanism. Determine the value of P that will prevent motion.

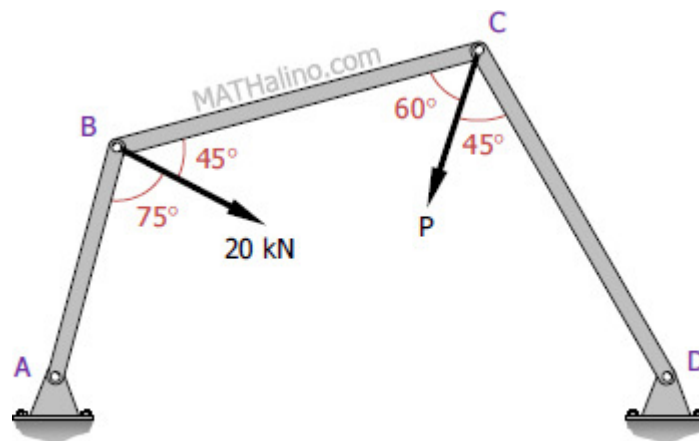
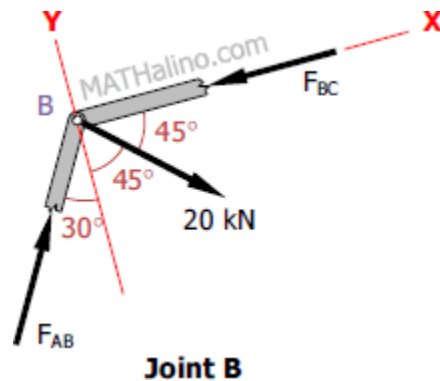

Figure P-318

### Solution 318

At joint B



$$\sum F'_y = 0$$

$$F_{AB} \cos 30^\circ = 20 \sin 45^\circ$$

$$F_{AB} = 16.33 \text{ kN}$$

$$\Sigma F_x = 0$$

$$F_{BC} = 20 \cos 45^\circ + F_{AB} \sin 30^\circ$$

$$F_{BC} = 20 \cos 45^\circ + 16.33 \sin 30^\circ$$

$$F_{BC} = 22.31 \text{ kN}$$

At joint C

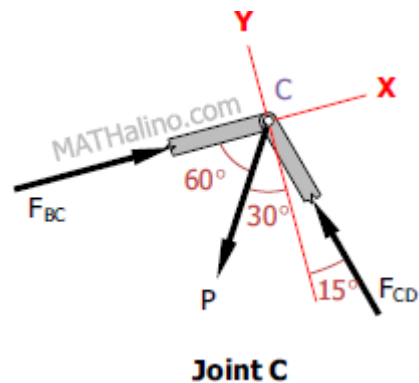

$$\Sigma F_y = 0$$

$$F_{CD} \cos 15^\circ = P \sin 60^\circ$$

$$F_{CD} = 0.8966P$$

$$\Sigma F_x = 0$$

$$P \cos 60^\circ + F_{CD} \sin 15^\circ = F_{BC}$$

$$P \cos 60^\circ + (0.8966P) \sin 15^\circ = 22.31$$

$$0.7320P = 22.31$$

$P = 30.48 \text{ kN}$      *answer*

## Problem 319 | Equilibrium of Concurrent Force System

Cords are loop around a small spacer separating two cylinders each weighing 400 lb and pass, as shown in Fig. P-319 over a frictionless pulleys to weights of 200 lb and 400 lb. Determine the angle  $\theta$  and the normal pressure  $N$  between the cylinders and the smooth horizontal surface.

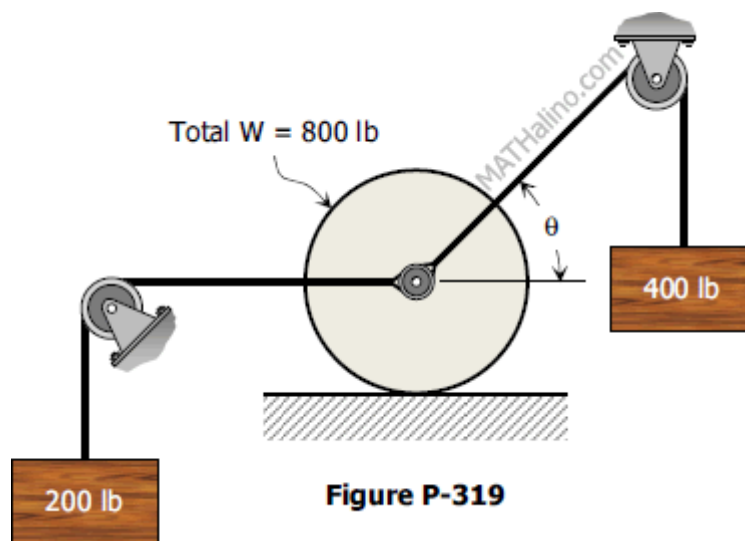

### Solution 319

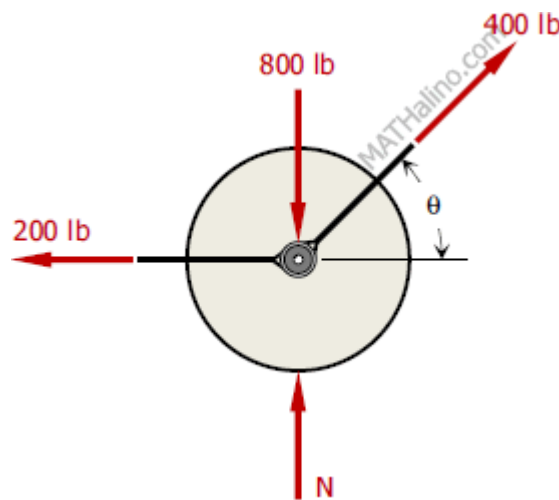

$$\Sigma F_H = 0$$

$$400 \cos \theta = 200$$

$$\cos \theta = 0.5$$

$$\theta = 60^\circ \quad \text{answer}$$

$$\Sigma F_V = 0$$

$$N + 400 \sin \theta = 800$$

$$N + 400 \sin 60^\circ = 800$$

$$N = 453.59 \text{ lb} \quad \text{answer}$$

## Problem 322 | Equilibrium of Force System

The Fink truss shown in [Fig. P-322](#) is supported by a roller at A and a hinge at B. The given loads are normal to the inclined member. Determine the reactions at A and B. Hint: Replace the loads by their resultant.

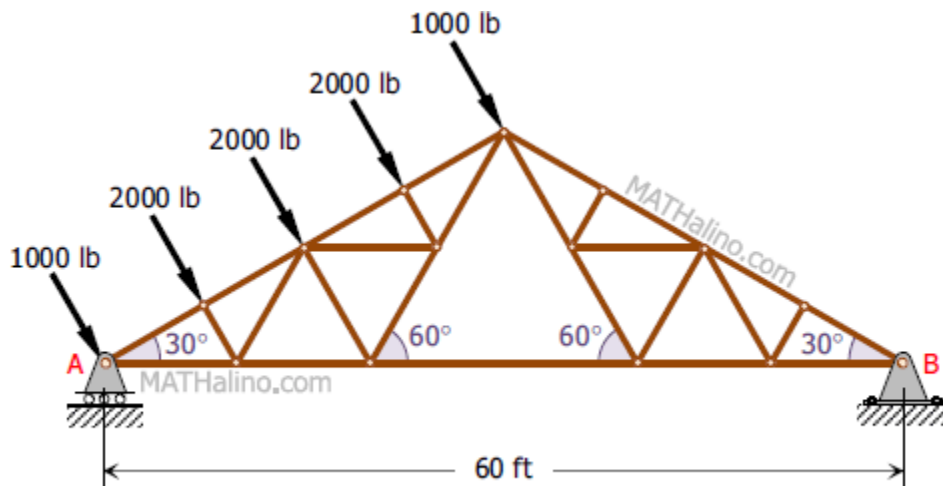
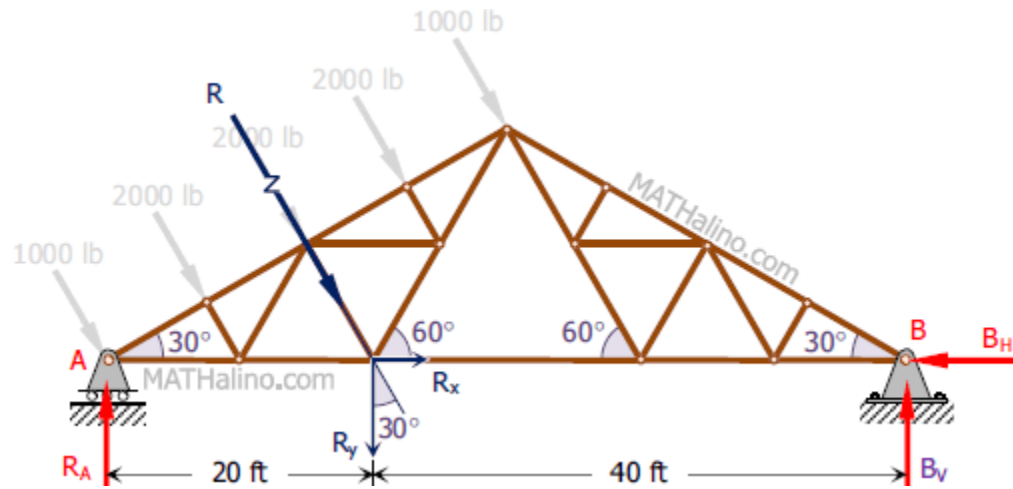

Figure P-322

**Solution 322**

$$R = 2(1000) + 3(2000)$$

$$R = 8000 \text{ lb}$$



$$R_x = R \sin 30^\circ$$

$$R_x = 8000 \sin 30^\circ$$

$$R_x = 4000 \text{ lb}$$

$$R_y = R \cos 30^\circ$$

$$R_y = 8000 \cos 30^\circ$$

$$R_y = 6928.20 \text{ lb}$$

$$\Sigma M_B = 0$$

$$60R_A = 40R_y$$

$$60R_A = 40(6928.20)$$

$$R_A = 4618.80 \text{ lb} \quad \text{answer}$$

$$\Sigma M_A = 0$$

$$60B_V = 20R_y$$

$$60B_V = 20(6958.20)$$

$$B_V = 2309.40 \text{ lb}$$

$$\Sigma F_H = 0$$

$$B_H = R_x$$

$$B_H = 4000 \text{ lb}$$

$$R_B = \sqrt{B_H^2 + B_V^2}$$

$$R_B = \sqrt{4000^2 + 2309.40^2}$$

$$R_B = 4618.80 \text{ lb}$$

$$\tan \theta_{B_x} = \frac{B_V}{B_H}$$

$$\tan \theta_{B_x} = \frac{2309.40}{4000}$$

$$\theta_{B_x} = 30^\circ$$

Thus,

$R_B = 4618.80 \text{ lb}$  at  $30^\circ$  with horizontal      *answer*

Another Solution

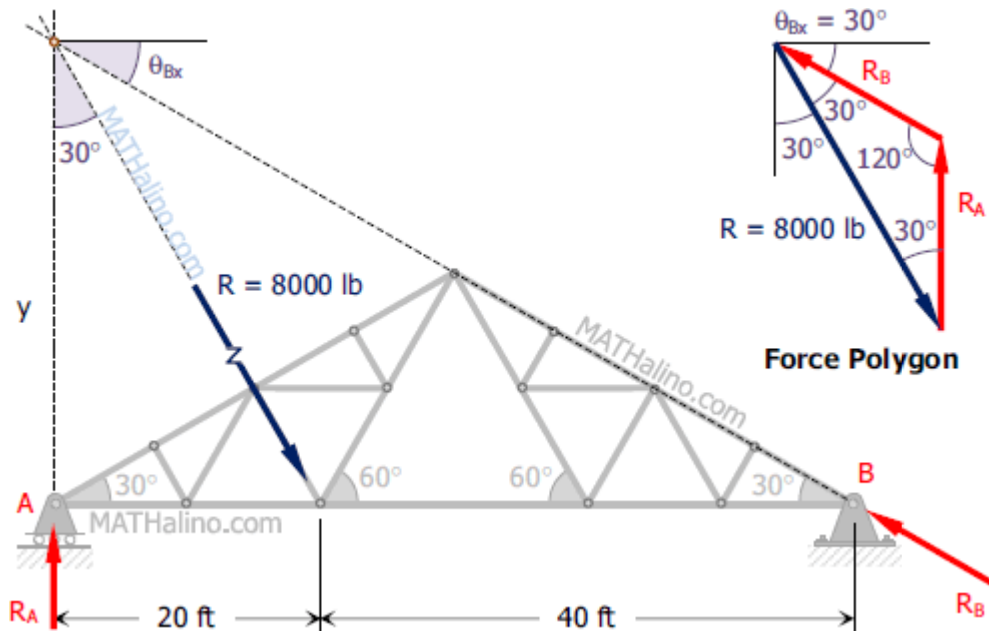

$$\tan 30^\circ = \frac{20}{y}$$

$$y = 34.64 \text{ ft}$$

$$\tan \theta_{Bx} = \frac{y}{60}$$

$$\tan \theta_{Bx} = \frac{34.64}{60}$$

$$\theta_{Bx} = 30^\circ \quad (\text{okay!})$$

From the Force Polygon

$$\frac{R_A}{\sin 30^\circ} = \frac{R_B}{\sin 30^\circ} = \frac{8000}{\sin 120^\circ}$$

$$R_A = 4618.80 \text{ lb} \quad (\text{okay!})$$

$$R_B = 4618.80 \text{ lb} \quad (\text{okay!})$$

## Problem 323 | Equilibrium of Force System

The truss shown in [Fig. P-323](#) is supported by a hinge at A and a roller at B. A load of 20 kN is applied at C. Determine the reactions at A and B.

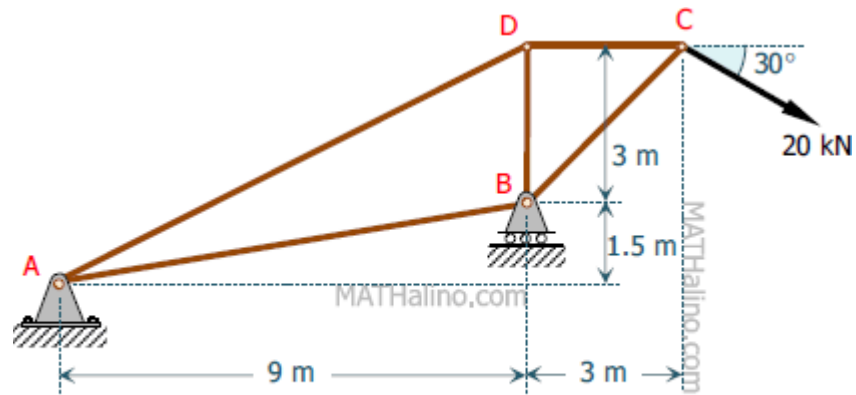

Figure P-323

**Solution 323**

$$\Sigma M_A = 0$$

$$9R_B = (3 + 1.5)(20 \cos 30^\circ) + (9 + 3)(20 \sin 30^\circ)$$

$$9R_B = 197.94$$

$$R_B = 21.99 \text{ kN} \quad \text{answer}$$

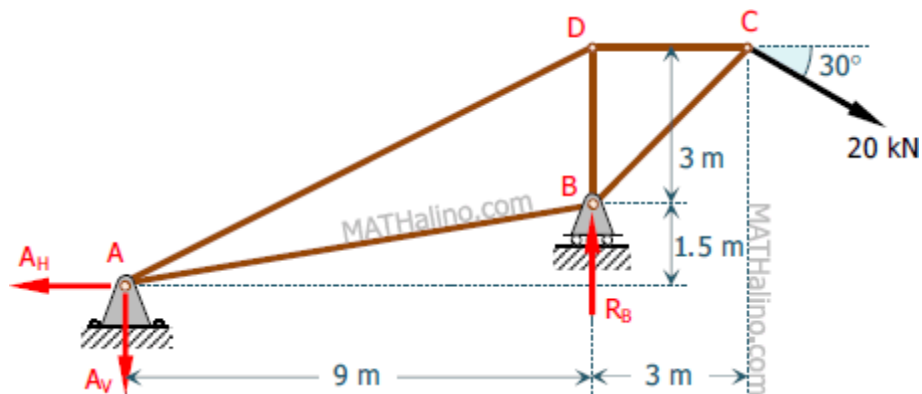

$$\Sigma F_H = 0$$

$$A_H = 20 \cos 30^\circ$$

$$A_H = 17.32 \text{ kN}$$

$$\Sigma M_B = 0$$

$$9A_V = 1.5A_H + 3(20 \cos 30^\circ) + 3(20 \sin 30^\circ)$$

$$9A_V = 1.5(17.32) + 3(20 \cos 30^\circ) + 3(20 \sin 30^\circ)$$

$$9A_V = 107.94$$

$$A_V = 11.99 \text{ kN}$$

$$R_A = \sqrt{A_H^2 + A_V^2}$$

$$R_A = \sqrt{17.32^2 + 11.99^2}$$

$$R_A = 21.06 \text{ kN}$$

$$\tan \theta_{Ax} = \frac{A_V}{A_H}$$

$$\tan \theta_{Ax} = \frac{11.99}{17.32}$$

$$\theta_{Ax} = 34.7^\circ$$

Thus,

$R_A = 21.06 \text{ kN}$  down to the left at  $34.7^\circ$  with the horizontal.

*answer*

### Another Solution

$$\tan 30^\circ = \frac{y}{3}$$

$$y = 1.732 \text{ m}$$

$$\tan \theta_{Ax} = \frac{y + 3 + 1.5}{9}$$

$$\tan \theta_{Ax} = \frac{1.732 + 3 + 1.5}{9}$$

$$\theta_{Ax} = 34.7^\circ \quad (\text{okay!})$$

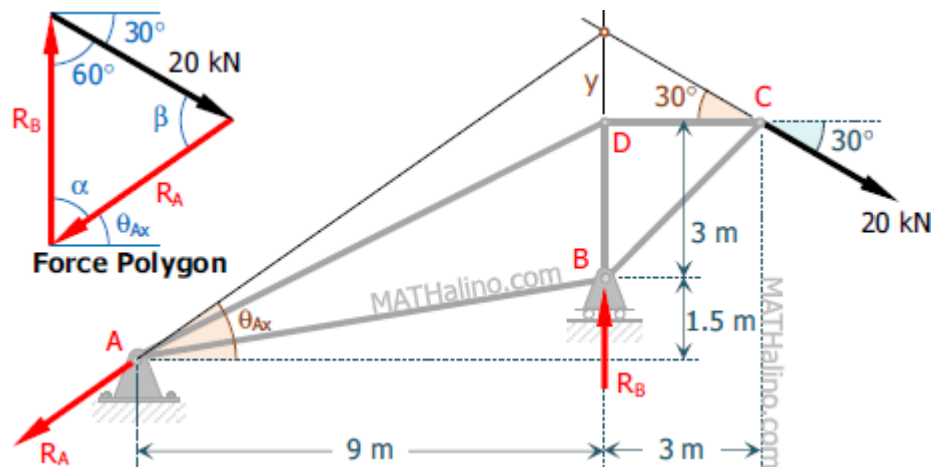

$$\alpha = 90^\circ - \theta_{Ax} = 90^\circ - 34.7^\circ$$

$$\alpha = 55.3^\circ$$

$$\beta = 180^\circ - \alpha - 60^\circ = 180^\circ - 55.3^\circ - 60^\circ$$

$$\beta = 64.7^\circ$$

$$\frac{R_A}{\sin 60^\circ} = \frac{R_B}{\sin 60^\circ} = \frac{20}{\sin \alpha}$$

$$\frac{R_A}{\sin 60^\circ} = \frac{R_B}{\sin 64.7^\circ} = \frac{R_A}{\sin 55.3^\circ}$$

$$R_A = 21.07 \text{ kN} \quad (\text{okay!})$$

$$R_B = 21.99 \text{ kN} \quad (\text{okay!})$$

## Problem 325 | Equilibrium of Three-force System

Determine the amount and direction of the smallest force  $P$  required to start the wheel in [Fig. P-325](#) over the block. What is the reaction at the block?

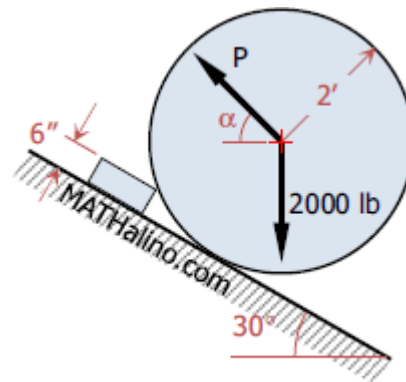

Figure P-325

**Solution 325**

$$\cos \beta = \frac{1.5}{2}$$

$$\beta = 41.41^\circ$$

$$30^\circ + \beta = 71.41^\circ$$

$$\phi = 18.59^\circ + \alpha$$

$$\theta = 90^\circ - \alpha$$

$$\frac{P}{\sin 71.41^\circ} = \frac{2000}{\sin \beta}$$

$$P = \frac{2000 \sin 71.41^\circ}{\sin(18.59^\circ + \alpha)}$$

$$\frac{dP}{d\alpha} = \frac{-2000 \sin 71.41^\circ \cos(18.59^\circ + \alpha)}{\sin^2(18.59^\circ + \alpha)} = 0$$

$$-2000 \sin 71.41^\circ \cos(18.59^\circ + \alpha) = 0$$

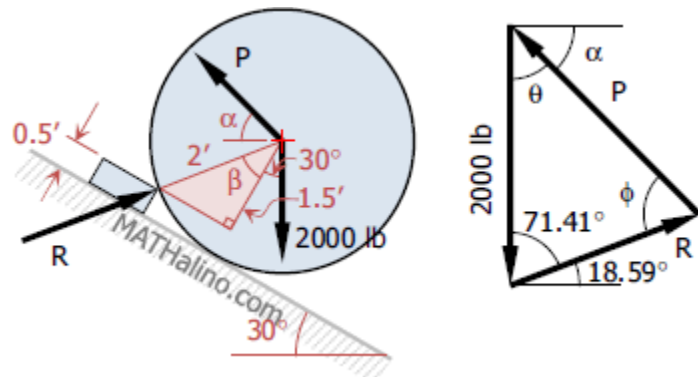

$$\cos(18.59^\circ + \alpha) = 0$$

$$18.59^\circ + \alpha = 90^\circ$$

$$\alpha = 71.41^\circ \quad \text{answer}$$

$$P_{min} = \frac{2000 \sin 71.41^\circ}{\sin(18.59^\circ + 71.41^\circ)}$$

$$P_{min} = 1895.65 \text{ lb} \quad \text{answer}$$

$$\phi = 18.59^\circ + 71.41^\circ = 90^\circ$$

$$\theta = 90^\circ - 71.41^\circ = 18.59^\circ$$

$$\frac{R}{\sin \theta} = \frac{2000}{\sin \phi}$$

$$\frac{R}{\sin 18.59^\circ} = \frac{2000}{\sin 90^\circ}$$

$$R = 637.59 \text{ lb} \quad \text{answer}$$

## Problem 326 | Equilibrium of Force System

The cylinders in [Fig. P-326](#) have the indicated weights and dimensions. Assuming smooth contact surfaces, determine the reactions at A, B, C, and D on the cylinders.

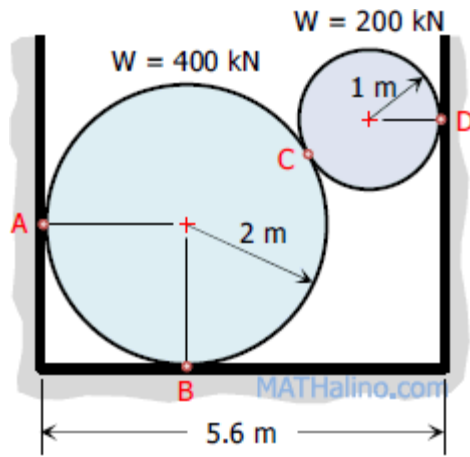
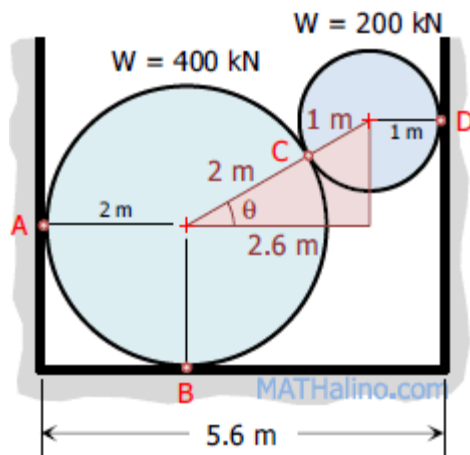

Figure P-326

Solution 326

$$\cos \theta = \frac{2.6}{2 + 1}$$

$$\theta = 29.93^\circ$$



From the FBD of 200 kN cylinder

$$\Sigma F_V = 0$$

$$R_C \sin \theta = 200$$

$$R_C \sin 29.93^\circ = 200$$

$$R_C = 400.85 \text{ kN} \quad \text{answer}$$

$$\Sigma F_H = 0$$

$$R_D = R_C \cos \theta$$

$$R_D = 400.85 \cos 29.93^\circ$$

$$R_D = 347.39 \text{ kN} \quad \text{answer}$$

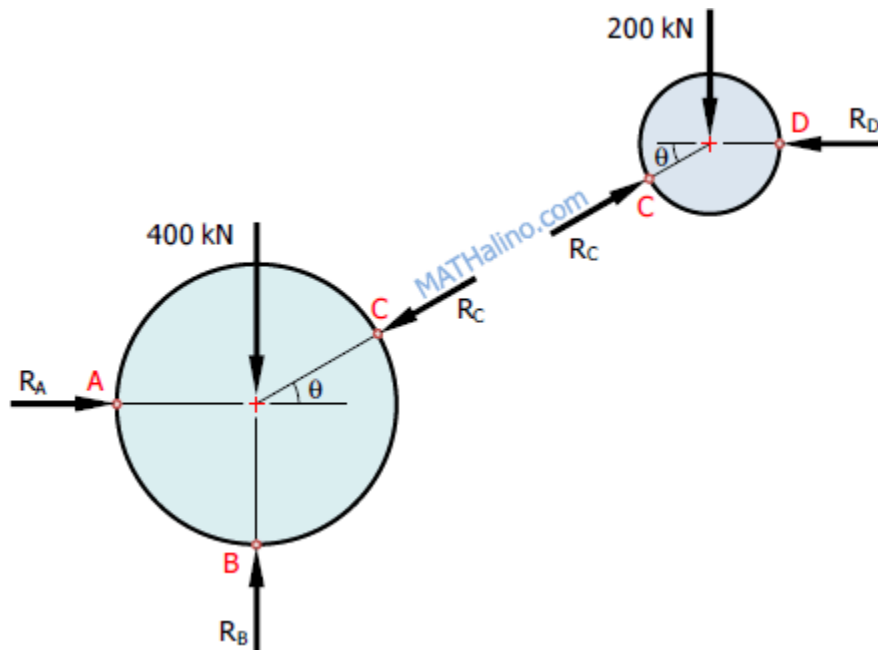

From the FBD of 400 kN cylinder

$$\Sigma F_H = 0$$

$$R_A = R_C \cos \theta$$

$$R_A = 400.85 \cos 29.93^\circ$$

$$R_A = 347.39 \text{ kN} \quad \text{answer}$$

$$\Sigma F_V = 0$$

$$R_B = 400 + R_C \sin \theta$$

$$R_B = 400 + 400.85 \sin 29.93^\circ$$

$$R_B = 600 \text{ kN} \quad \text{answer}$$

## Problem 327 | Equilibrium of Force System

Forces  $P$  and  $F$  acting along the bars shown in [Fig. P-327](#) maintain equilibrium of pin  $A$ . Determine the values of  $P$  and  $F$ .

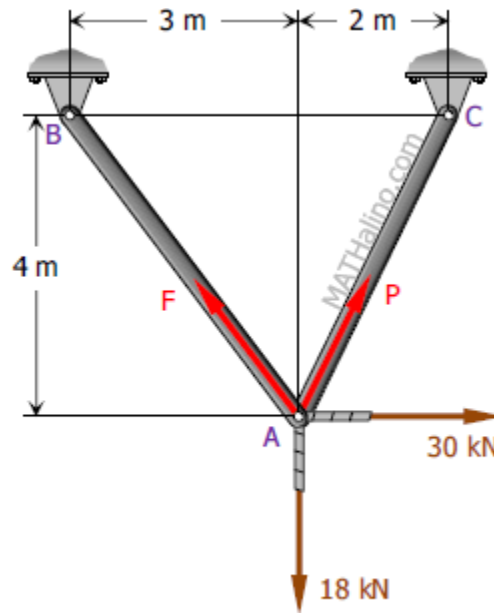

Figure P-327

### Solution 327

$$\sum F_H = 0$$

$$F\left(\frac{3}{5}\right) = P\left(\frac{1}{\sqrt{5}}\right) + 30$$

$$F = \frac{\sqrt{5}}{3}P + 50 \quad \rightarrow \text{Equation (1)}$$

$$\sum F_V = 0$$

$$P\left(\frac{2}{\sqrt{5}}\right) + F\left(\frac{4}{5}\right) = 18$$

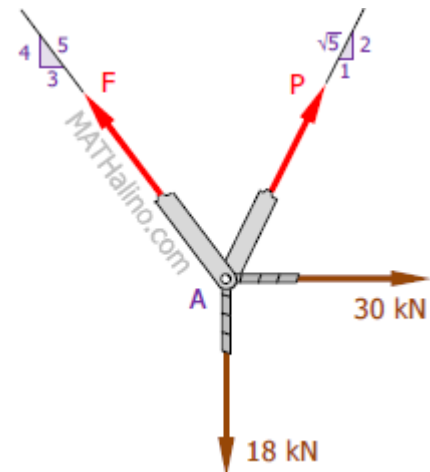

$$\frac{\sqrt{5}}{2}P + F = 22.5$$

Substitute F of Equation (1)

$$\frac{\sqrt{5}}{2}P + \left(\frac{\sqrt{5}}{3}P + 50\right) = 22.5$$

$$\frac{5\sqrt{5}}{6}P = -27.5$$

$$P = -14.76 \text{ kN} \quad \text{answer}$$

From Equation (1)

$$F = \frac{\sqrt{5}}{3}(-14.76) + 50$$

$$F = 39 \text{ kN} \quad \text{answer}$$

## Problem 328 | Equilibrium of Force System

Two weightless bars pinned together as shown in Fig. P-328 support a load of 35 kN. Determine the forces P and F acting respectively along bars AB and AC that maintain equilibrium of pin A.

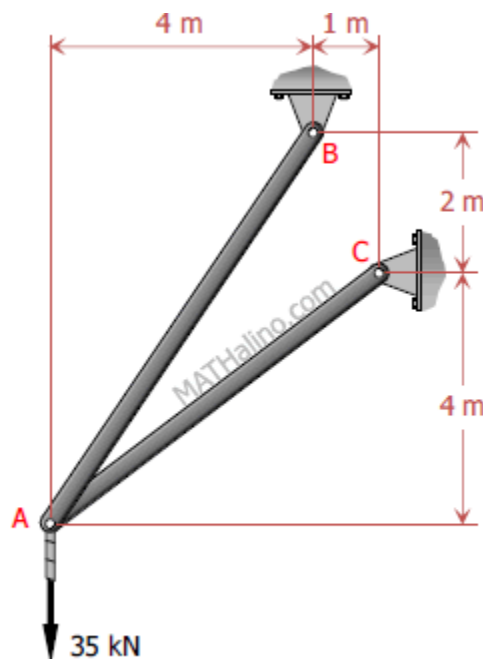

Figure P-328

### Solution 328

$$\Sigma F_H = 0$$

$$F\left(\frac{5}{\sqrt{41}}\right) = P\left(\frac{2}{\sqrt{13}}\right)$$

$$F = 0.7104P$$

$$\Sigma F_V = 0$$

$$P\left(\frac{3}{\sqrt{13}}\right) = F\left(\frac{4}{\sqrt{41}}\right) + 35$$

$$0.3883P = 35$$

$$P = 90.14 \text{ kN} \quad \text{answer}$$

$$F = 0.7104(90.14)$$

$$F = 64.03 \text{ kN} \quad \text{answer}$$

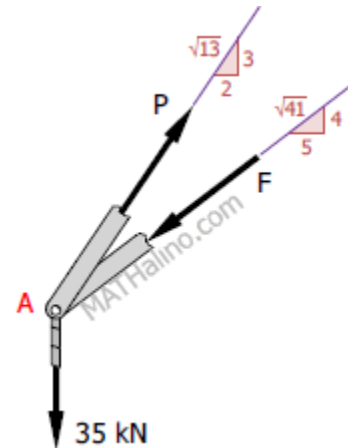

## 2. Equilibrium of Parallel Force System

### Conditions for Equilibrium of Parallel Forces

The sum of all the forces is zero.

$$\Sigma F = 0$$

The sum of moment at any point O is zero.

$$\Sigma M_O = 0$$

## Problem 329 | Equilibrium of Force System

Two cylinders A and B, weighing 100 lb and 200 lb respectively, are connected by a rigid rod curved parallel to the smooth cylindrical surface shown in [Fig. P-329](#). Determine the angles  $\alpha$  and  $\beta$  that define the position of equilibrium.

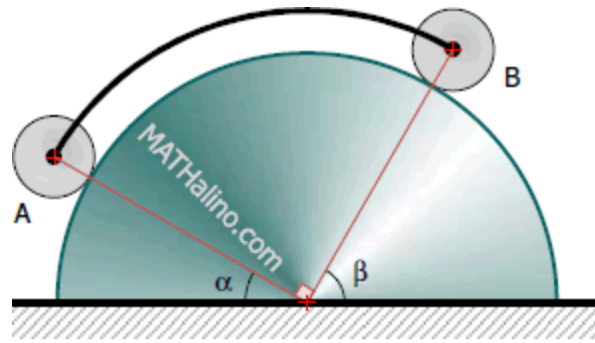

Figure P-329

Solution 329

$$\sum M_O = 0$$

$$100R \cos \alpha = 200R \cos \beta$$

$$\cos \alpha = 2 \cos \beta$$

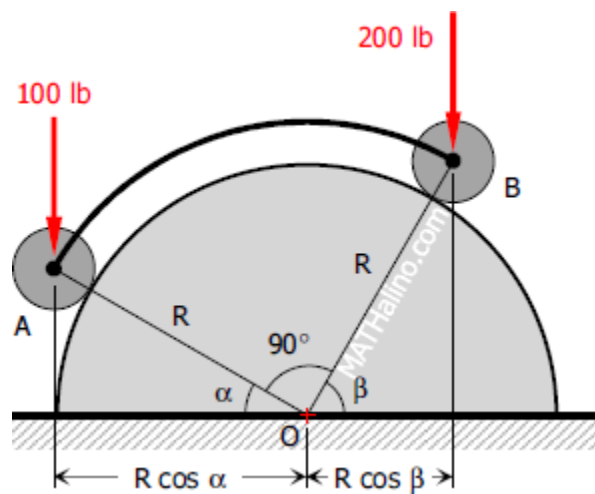

From the figure

$$\alpha + \beta = 90^\circ$$

$$\alpha = 90^\circ - \beta$$

Thus,

$$\cos(90^\circ - \beta) = 2 \cos \beta$$

$$\sin \beta = 2 \cos \beta$$

$$\frac{\sin \beta}{\cos \beta} = 2$$

$$\tan \beta = 2$$

$$\beta = 63.43^\circ \quad \text{answer}$$

$$\alpha = 90^\circ - 63.43^\circ$$

$$\alpha = 26.57^\circ \quad \text{answer}$$

## Problem 332 | Equilibrium of Parallel Force System

Determine the reactions for the beam shown in Fig. P-332.

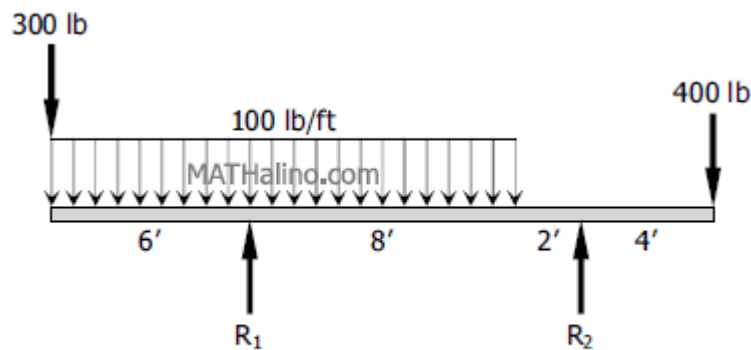

Figure P-332

### Solution 332

$$\sum M_{R_2} = 0$$

$$10R_1 + 4(400) = 16(300) + 9[14(100)]$$

$$R_1 = 1580 \text{ lb} \quad \text{answer}$$

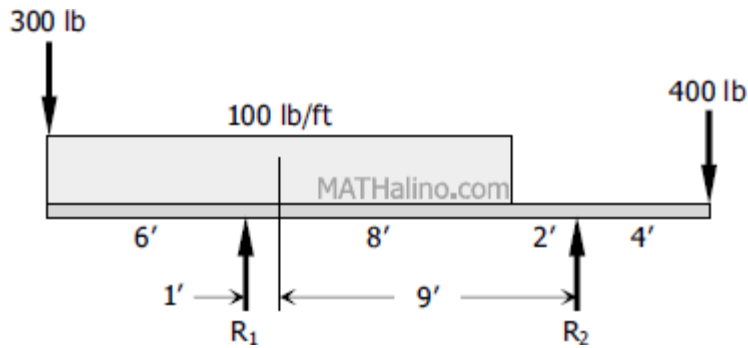

$$\sum M_{R1} = 0$$

$$10R_2 + 6(300) = 14(400) + 1[14(100)]$$

$$R_2 = 520 \text{ lb} \quad \text{answer}$$

## Problem 333 | Equilibrium of Parallel Force System

Determine the reactions  $R_1$  and  $R_2$  of the beam in Fig. P-333 loaded with a concentrated load of 1600 lb and a load varying from zero to an intensity of 400 lb per ft.

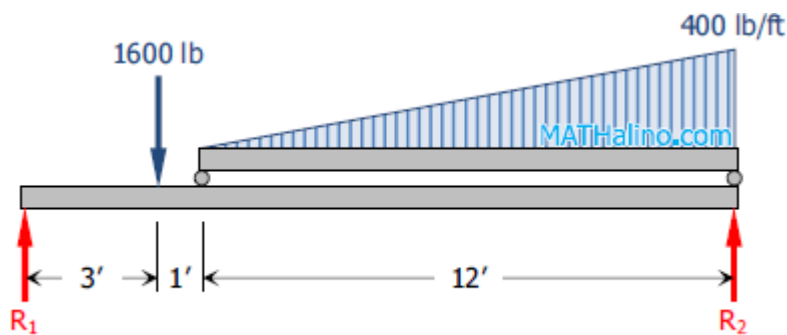

Figure P-333

### Solution 333

$$\sum M_{R2} = 0$$

$$12R_3 = 4\left[\frac{1}{2}(12)(400)\right]$$

$$R_3 = 800 \text{ lb}$$

$$\Sigma M_{R_3} = 0$$

$$12R_4 = 8\left[\frac{1}{2}(12)(400)\right]$$

$$R_4 = 1600 \text{ lb}$$

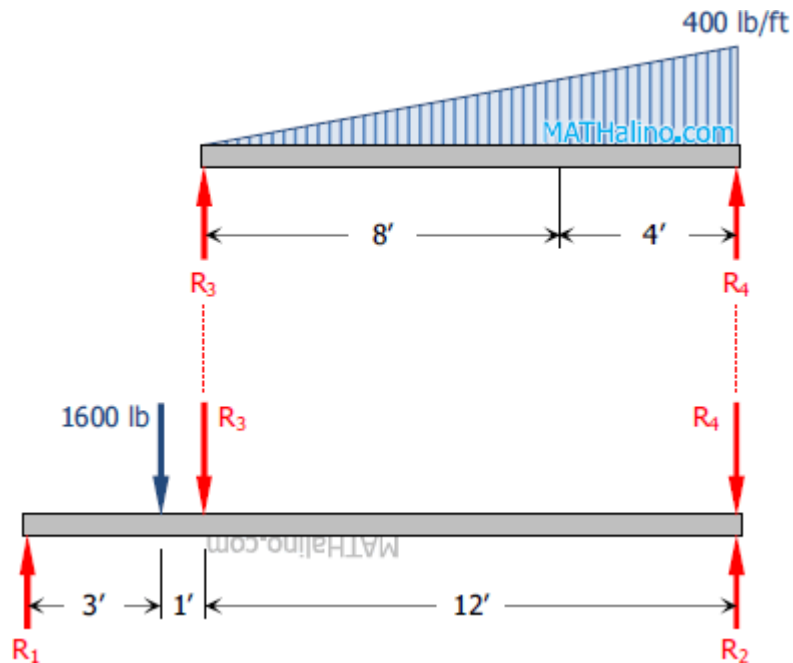

$$\Sigma M_{R_2} = 0$$

$$16R_1 = 13(1600) + 12R_3$$

$$16R_1 = 13(1600) + 12(800)$$

$$R_1 = 1900 \text{ lb} \quad \text{answer}$$

$$\Sigma M_{R_1} = 0$$

$$16R_2 = 3(1600) + 4R_3 + 16R_4$$

$$16R_2 = 3(1600) + 4(800) + 16(1600)$$

$$R_2 = 2100 \text{ lb}$$

*answer*

## Problem 334 | Equilibrium of Parallel Force System

Determine the reactions for the beam loaded as shown in Fig. P-334.

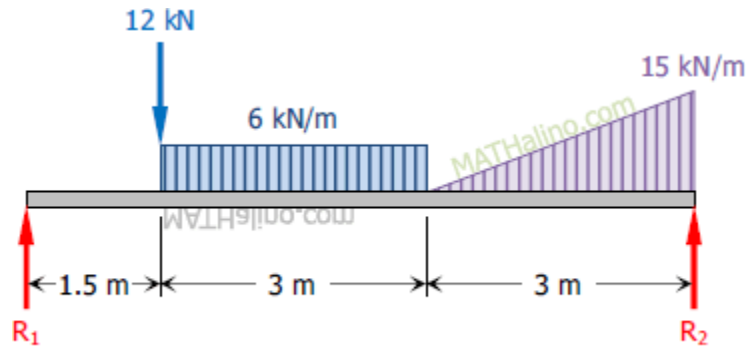

Figure P-334

### Solution 334

$$\Sigma M_{R_2} = 0$$

$$7.5R_1 = 6(12) + 4.5[3(6)] + 1\left[\frac{1}{2}(3)(15)\right]$$

$$R_1 = 23.4 \text{ kN} \quad \textit{answer}$$

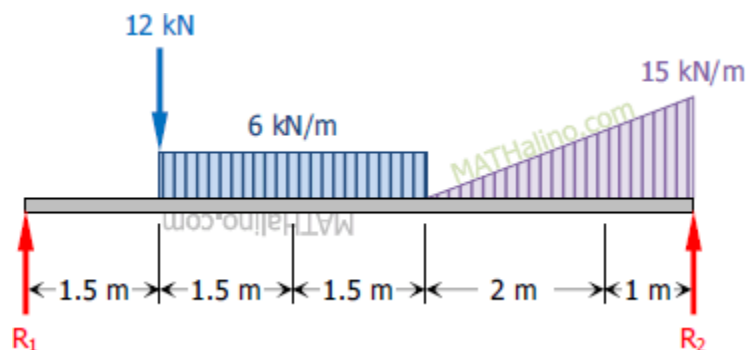

$$\Sigma M_{R_1} = 0$$

$$7.5R_2 = 1.5(12) + 3[3(6)] + 6.5\left[\frac{1}{2}(3)(15)\right]$$

$$R_2 = 29.1 \text{ kN} \quad \text{answer}$$

## Problem 335 | Equilibrium of Parallel Force System

The roof truss in Fig. P-335 is supported by a roller at A and a hinge at B. Find the values of the reactions.

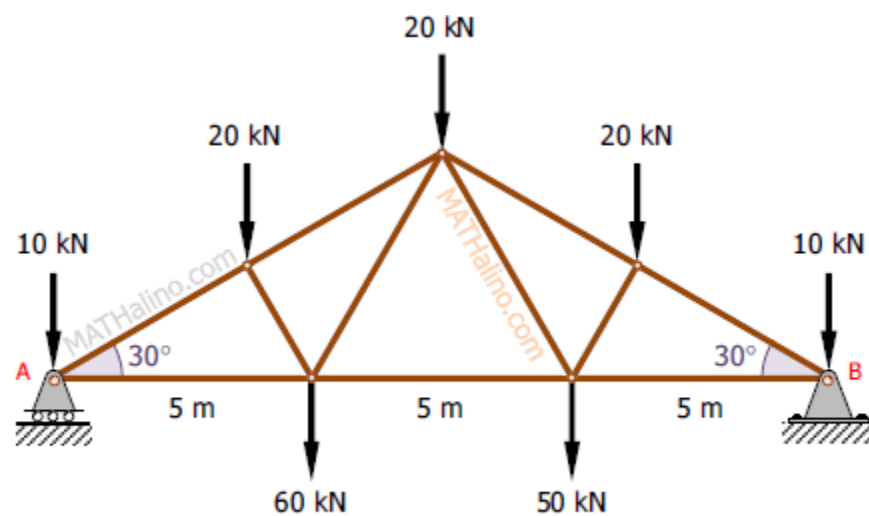

Figure P-335

### Solution 335

$$\sum M_B = 0$$

$$15R_A = 10(60) + 7.5(80) + 5(50)$$

$$R_A = 96.67 \text{ kN} \quad \text{answer}$$

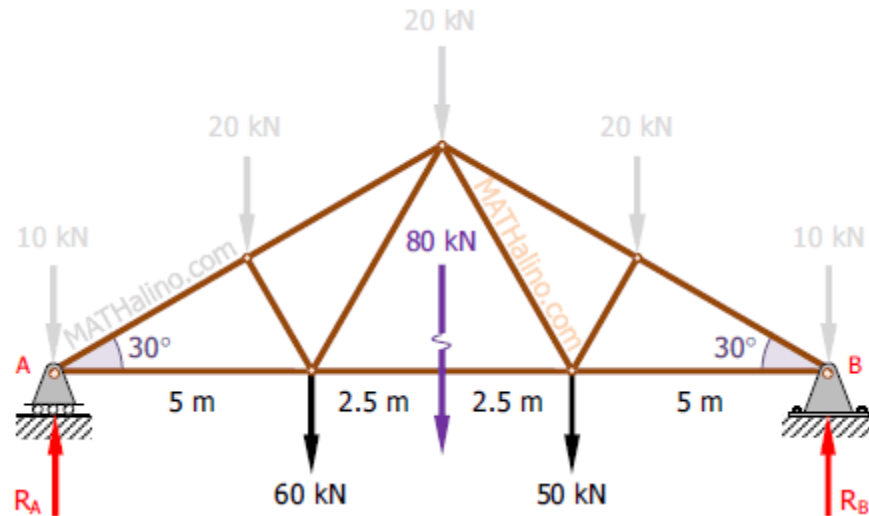

$$\sum M_A = 0$$

$$15R_B = 5(60) + 7.5(80) + 10(50)$$

$$R_B = 93.33 \text{ kN} \quad \text{answer}$$

## Problem 336 | Equilibrium of Parallel Force System

The cantilever beam shown in Fig. P-336 is built into a wall 2 ft thick so that it rests against points A and B. The beam is 12 ft long and weighs 100 lb per ft.

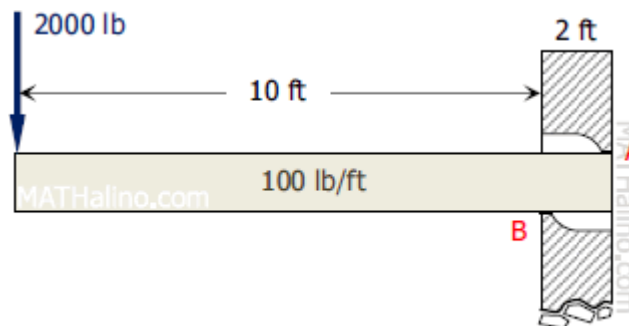

Figure P-336

### Solution 336

$$\Sigma M_B = 0$$

$$2R_A = 10(2000) + 4[12(100)]$$

$$R_A = 12\,400 \text{ lb} \quad \text{answer}$$

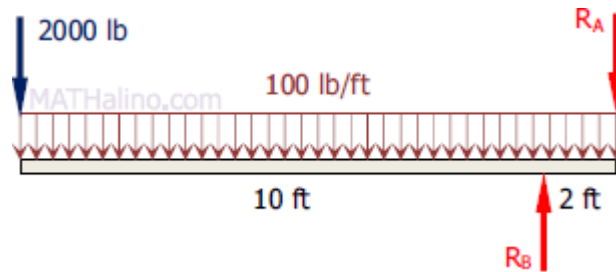

$$\Sigma M_A = 0$$

$$2R_B = 12(2000) + 6[12(100)]$$

$$R_B = 15\,600 \text{ lb} \quad \text{answer}$$

## Problem 337 | Equilibrium of Parallel Force System

The upper beam in Fig. P-337 is supported at D and a roller at C which separates the upper and lower beams. Determine the values of the reactions at A, B, C, and D. Neglect the weight of the beams.

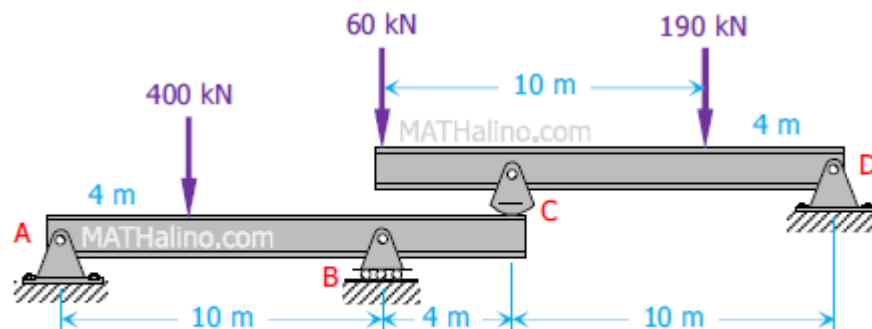

Figure P-337

**Solution 337**

$$\Sigma M_C = 0$$

$$10R_D + 4(60) = 6(190)$$

$$R_D = 90 \text{ kN} \quad \text{answer}$$

$$\Sigma M_D = 0$$

$$10R_C = 14(60) + 4(190)$$

$$R_C = 160 \text{ kN} \quad \text{answer}$$

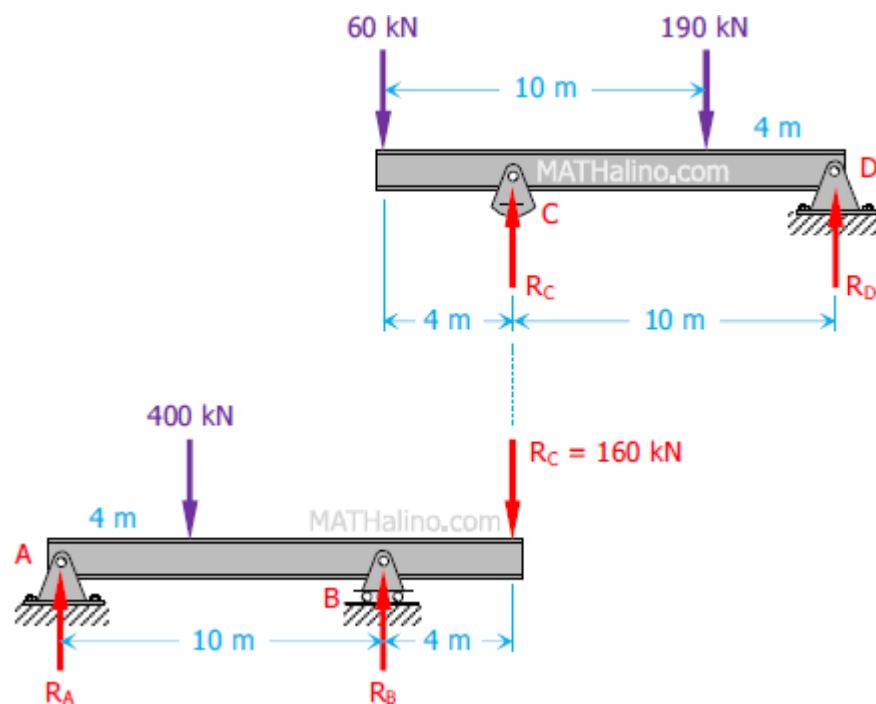

$$\Sigma M_A = 0$$

$$10R_B = 4(400) + 14(160)$$

$$R_B = 384 \text{ kN} \quad \text{answer}$$

$$\Sigma M_B = 0$$

$$10R_A + 4(160) = 6(400)$$

$$R_A = 176 \text{ kN} \quad \text{answer}$$

## Problem 338 | Equilibrium of Parallel Force System

The two 12-ft beams shown in Fig. 3-16 are to be moved horizontally with respect to each other and load P shifted to a new position on CD so that all three reactions are equal. How far apart will  $R_2$  and  $R_3$  then be? How far will P be from D?

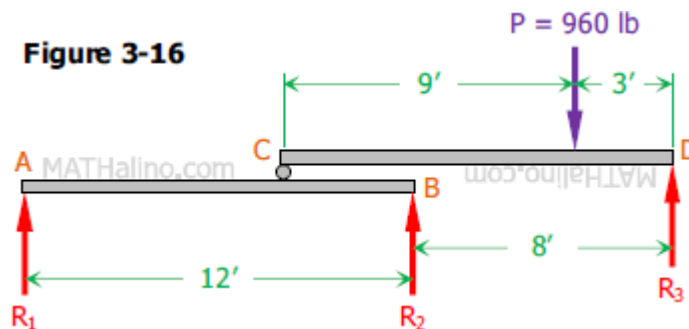

### Solution 338

From FBD of beam CD

$$\Sigma F_V = 0$$

$$R_C + R_3 = P$$

$$R_C + 0.5R_C = 960$$

$$R_C = 640 \text{ lb}$$

$$R_3 = 0.5(640) = 320 \text{ lb} \quad \text{answer}$$

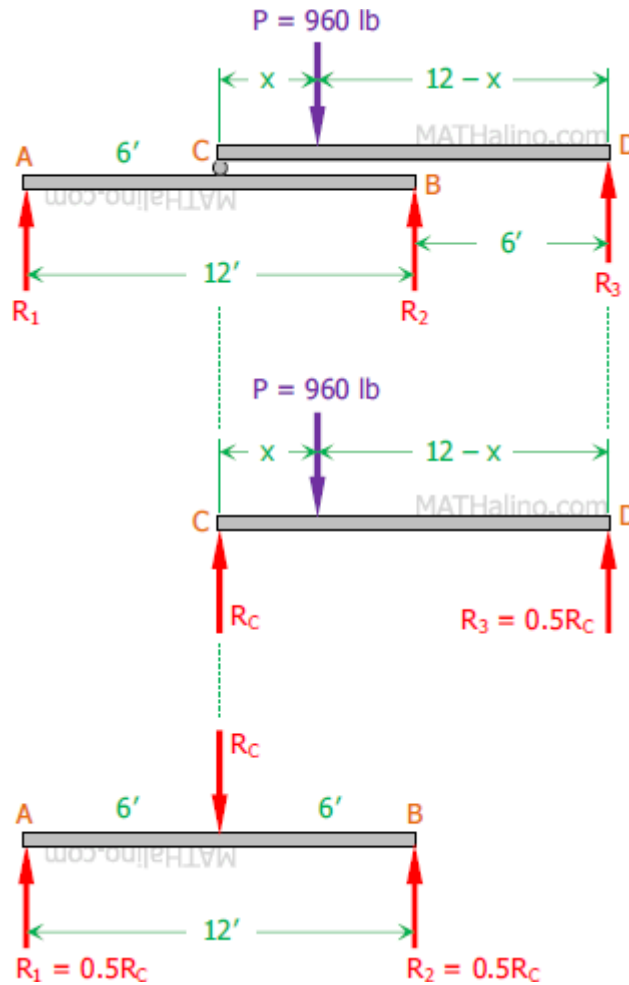

$$\Sigma M_C = 0$$

$$12R_3 = 960x$$

$$12(320) = 960x$$

$$x = 4 \text{ ft}$$

Thus, P is 8 ft to the left of D. *answer*

From the figure above,  $R_c$  is at the midspan of AB to produce equal reactions  $R_1$  and  $R_2$ . Thus,  $R_2$  and  $R_3$  are 6 ft apart. *answer*

From FBD of beam AB

$$R_1 = 0.5(640) = 320 \text{ lb} \quad \textit{answer}$$

$$R_2 = 0.5(640) = 320 \text{ lb} \quad \text{answer}$$

## Problem 339 | Equilibrium of Parallel Force System

The differential chain hoist shown in [Fig. P-339](#) consists of two concentric pulleys rigidly fastened together. The pulleys form two sprockets for an endless chain looped over them in two loops. In one loop is mounted a movable pulley supporting a load  $W$ . Neglecting friction, determine the maximum load  $W$  that can just be raised by a pull  $P$  supplied as shown.

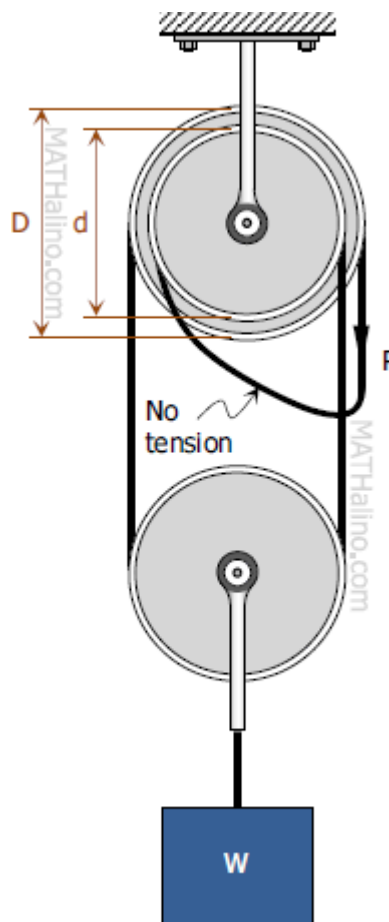
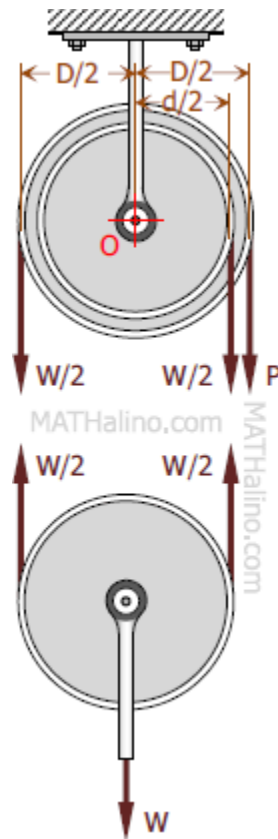

Figure P-339

### Solution 339

$$\Sigma M_O = 0$$

$$\frac{1}{2}W\left(\frac{1}{2}D\right) = P\left(\frac{1}{2}D\right) + \frac{1}{2}W\left(\frac{1}{2}d\right)$$



$$\frac{1}{4}WD = \frac{1}{2}PD + \frac{1}{4}Wd$$

$$\frac{1}{4}WD - \frac{1}{4}Wd = \frac{1}{2}PD$$

$$\frac{1}{4}(D - d)W = \frac{1}{2}PD$$

$$W = \frac{\frac{1}{2}PD}{\frac{1}{4}(D - d)}$$

$$W = \frac{2PD}{D - d} \quad \text{answer}$$

# Problem 340 - 341 | Equilibrium of Parallel Force System

## Problem 340

For the system of pulleys shown in [Fig. P-340](#), determine the ratio of  $W$  to  $P$  to maintain equilibrium. Neglect axle friction and the weights of the pulleys.

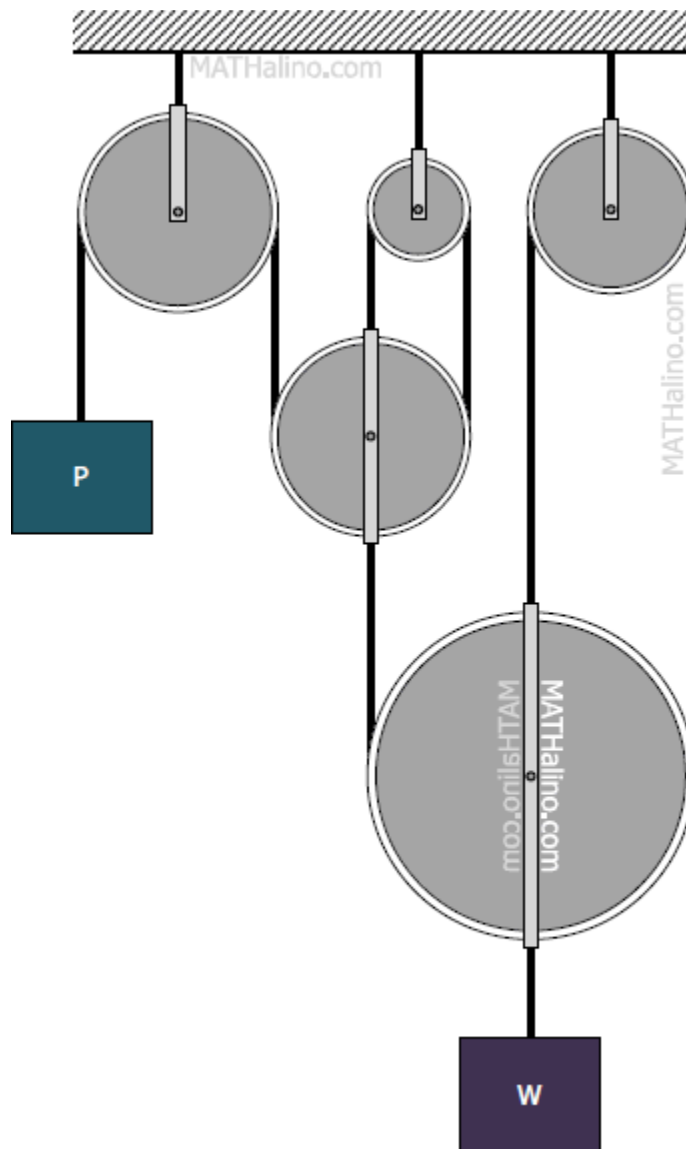
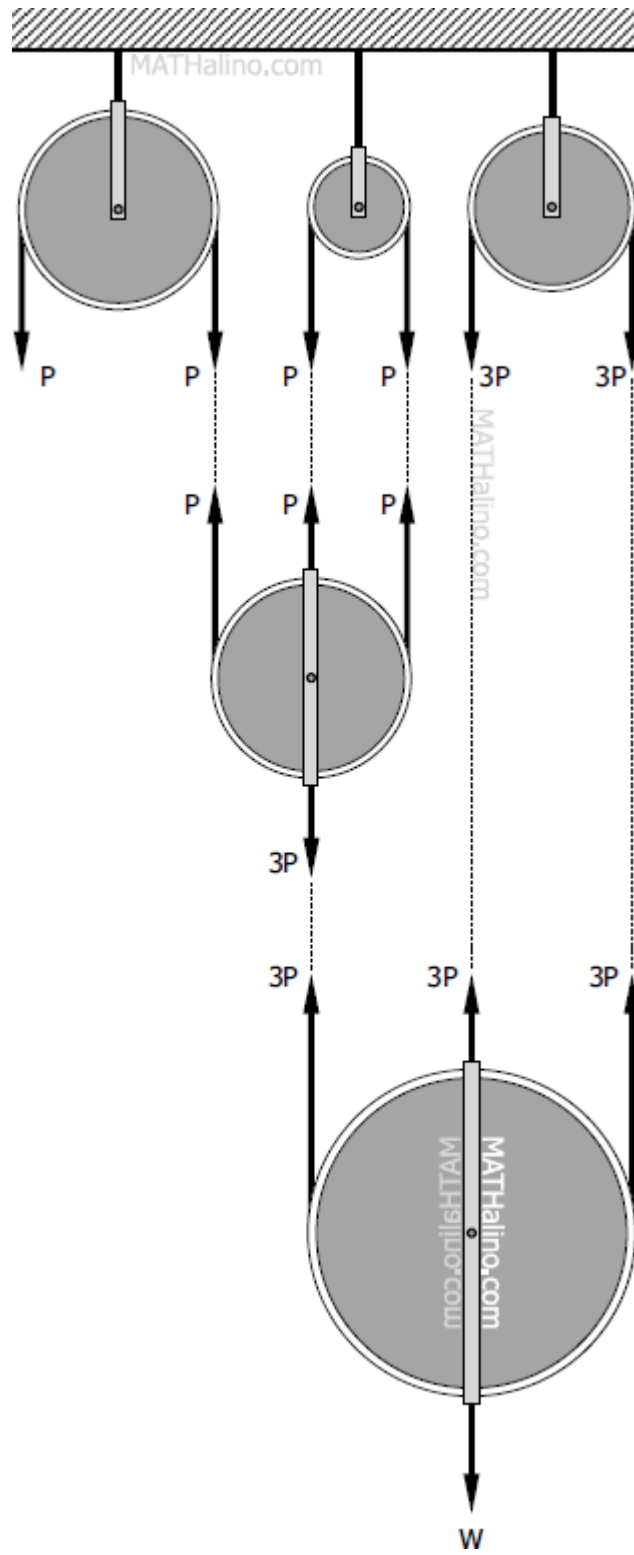

Figure P-340 and P-341

Solution 340



From the lowermost pulley

$$\Sigma F_V = 0$$

$$W = 9P$$

$$W/P = 9 \quad \text{answer}$$

### Problem 341

If each pulley shown in Fig. P-340 weighs 36 kg and  $W = 720$  kg, find  $P$  to maintain equilibrium.

### Solution 341

From pulley A

$$\Sigma F_V = 0$$

$$3T_1 = 36 + 720$$

$$3T_1 = 756$$

$$T_1 = 252 \text{ kg}$$

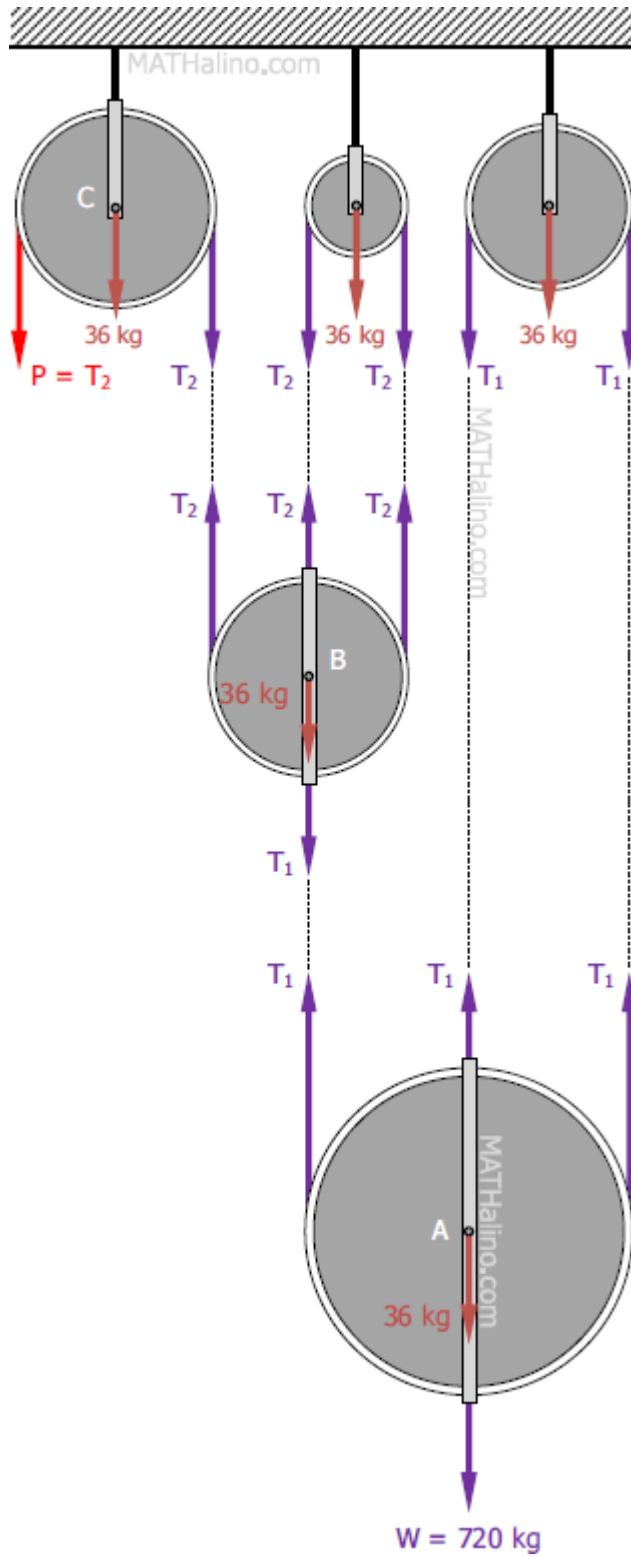

From pulley B  
 $\Sigma F_V = 0$

$$3T_2 = 36 + T_1$$

$$3T_2 = 36 + 252$$

$$3T_2 = 288$$

$$T_2 = 96 \text{ kg}$$

From pulley C  
 $P = T_2$

Thus,  $P = 96 \text{ kg}$       *answer*

## Problem 342 | Equilibrium of Parallel Force System

The wheel loads on a jeep are given in [Fig. P-342](#). Determine the distance  $x$  so that the reaction of the beam at A is twice as great as the reaction at B.

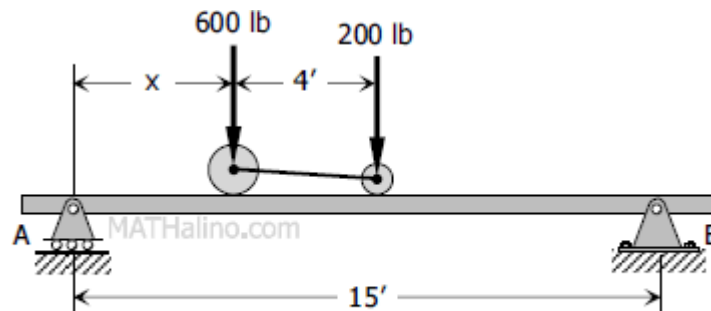
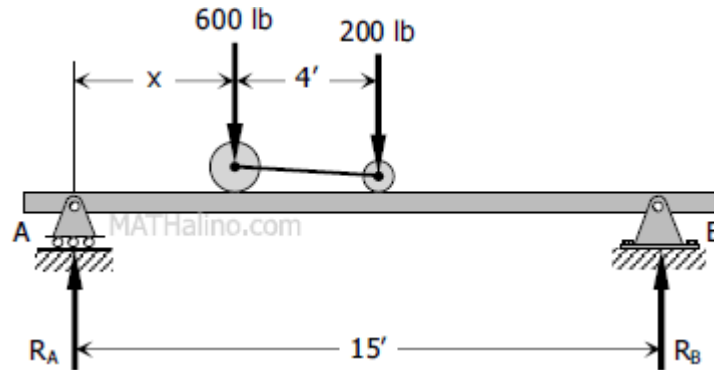

**Figure P-342**

### Solution 342

The reaction at A is twice as the reaction at B

$$R_A = 2R_B$$



$$\Sigma F_V = 0$$

$$R_A + R_B = 600 + 200$$

$$2R_B + R_B = 800$$

$$3R_B = 800$$

$$R_B = 266.67 \text{ lb}$$

$$\Sigma M_A = 0$$

$$600x + 200(x + 4) = 15R_B$$

$$600x + 200x + 800 = 15(266.67)$$

$$800x = 3200$$

$$x = 4 \text{ ft} \quad \text{answer}$$

## Problem 343 | Equilibrium of Parallel Force System

The weight  $W$  of a traveling crane is 20 tons acting as shown in [Fig. P-343](#). To prevent the crane from tipping to the right when carrying a load  $P$  of 20 tons, a counterweight  $Q$  is used. Determine the value and position of  $Q$  so that the crane will remain in equilibrium both when the maximum load  $P$  is applied and when the load  $P$  is removed.

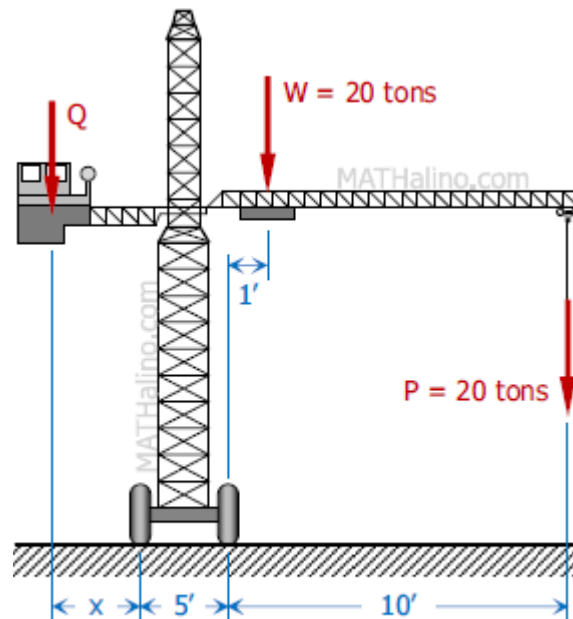

**Figure P-343**

**Solution 343**

When load  $P$  is removed

$$\sum M_A = 0$$

$$Qx = 20(5 + 1)$$

$$Qx = 120 \quad \rightarrow \text{Equation (1)}$$

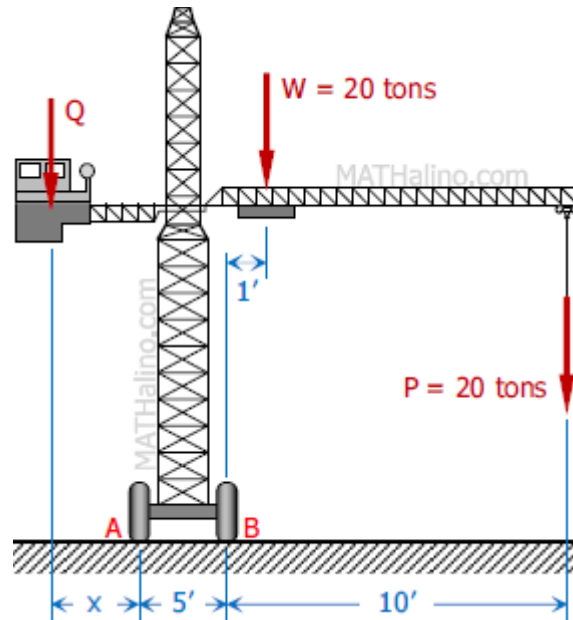

When load P is applied

$$\Sigma M_B = 0$$

$$Q(x + 5) = 20(1) + 20(10)$$

$$Qx + 5Q = 220$$

From Equation (1),  $Qx = 120$ , thus,

$$120 + 5Q = 220$$

$$5Q = 100$$

$$Q = 20 \text{ tons} \quad \text{answer}$$

Substitute  $Q = 20$  tons to Equation (1)

$$20x = 120$$

$$x = 6 \text{ ft} \quad \text{answer}$$

### 3. Equilibrium of Non-Concurrent Force System

# Problem 346 | Equilibrium of Non-Concurrent Force System

- [boom](#)
- [cable](#)
- [equilibrium](#)
- [non-concurrent forces](#)
- [non-parallel forces](#)
- [reaction](#)
- [static equilibrium](#)
- [support reaction](#)
- [tensile force](#)
- [tension member](#)

## Problem 346

A boom AB is supported in a horizontal position by a hinge A and a cable which runs from C over a small pulley at D as shown in [Fig. P-346](#). Compute the tension  $T$  in the cable and the horizontal and vertical components of the reaction at A. Neglect the size of the pulley at D.

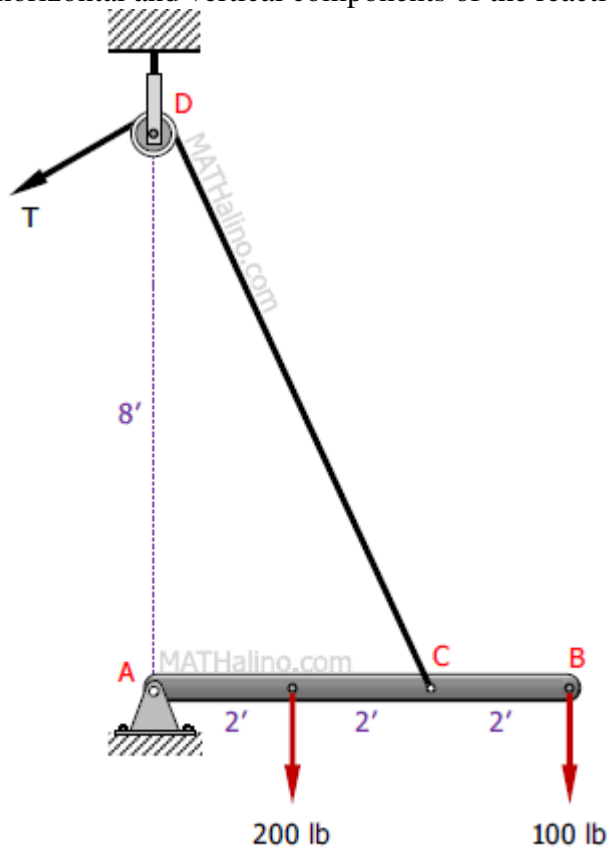

Figure P-346 and P-347

### Solution 346

$$\Sigma M_A = 0$$

$$4\left(\frac{2}{\sqrt{5}}T\right) = 2(200) + 6(100)$$

$$T = 279.51 \text{ lb} \quad \text{answer}$$

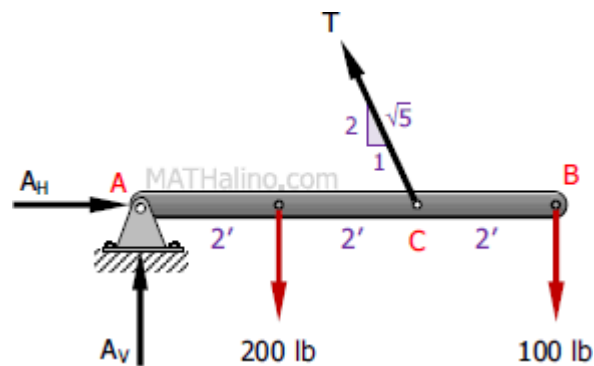

$$\Sigma F_V = 0$$

$$A_V + \frac{2}{\sqrt{5}}T = 200 + 100$$

$$A_V + \frac{2}{\sqrt{5}}(279.51) = 300$$

$$A_V = 50 \text{ lb} \quad \text{answer}$$

$$\Sigma F_H = 0$$

$$A_H = \frac{1}{\sqrt{5}}T$$

$$A_H = \frac{1}{\sqrt{5}}(279.51)$$

$$A_H = 62.5 \text{ lb} \quad \text{answer}$$

## Problem 347 | Equilibrium of Non-Concurrent Force System

- [boom](#)
- [cable](#)
- [equilibrium](#)
- [non-concurrent forces](#)
- [non-parallel forces](#)
- [reaction](#)
- [static equilibrium](#)
- [support reaction](#)
- [tensile force](#)
- [tension member](#)

### Problem 347

Repeat [Problem 346](#) if the cable pulls the boom AB into a position at which it is inclined at  $30^\circ$  above the horizontal. The loads remain vertical.

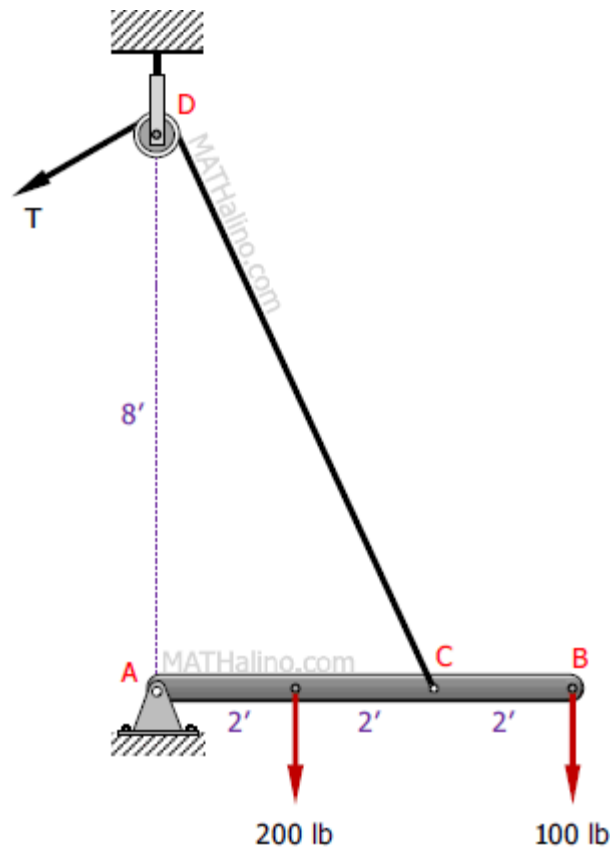

Figure P-346 and P-347

### Solution 347

$$\sin 60^\circ = \frac{x}{4}$$

$$x = 4 \sin 60^\circ$$

$$\tan \theta = \frac{6}{x}$$

$$\tan \theta = \frac{6}{4 \sin 60^\circ}$$

$$\tan \theta = \sqrt{3}$$

$$\theta = 60^\circ$$

Because  $\theta = 60^\circ$ ,  $T$  is perpendicular to  $AB$ .

$$\Sigma M_A = 0$$

$$4T = 200(2 \cos 30^\circ) + 100(6 \cos 30^\circ)$$

$$T = 216.51 \text{ lb} \quad \text{answer}$$

$$\Sigma F_H = 0$$

$$A_H = T \cos \theta$$

$$A_H = 216.51 \cos 60^\circ$$

$$A_H = 108.25 \text{ lb} \quad \text{answer}$$

$$\Sigma F_V = 0$$

$$A_V + T \sin \theta = 200 + 100$$

$$A_V + 216.51 \sin 60^\circ = 200 + 100$$

$$A_V = 112.50 \text{ lb} \quad \text{answer}$$

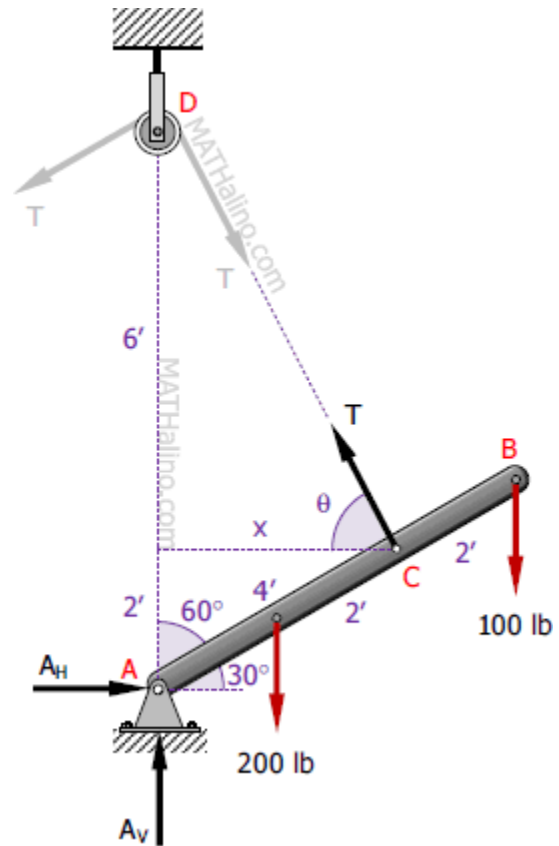

# Problem 348 | Equilibrium of Non-Concurrent Force System

## Problem 348

The frame shown in [Fig. P-348](#) is supported in pivots at A and B. Each member weighs 5 kN/m. Compute the horizontal reaction at A and the horizontal and vertical components of the reaction at B.

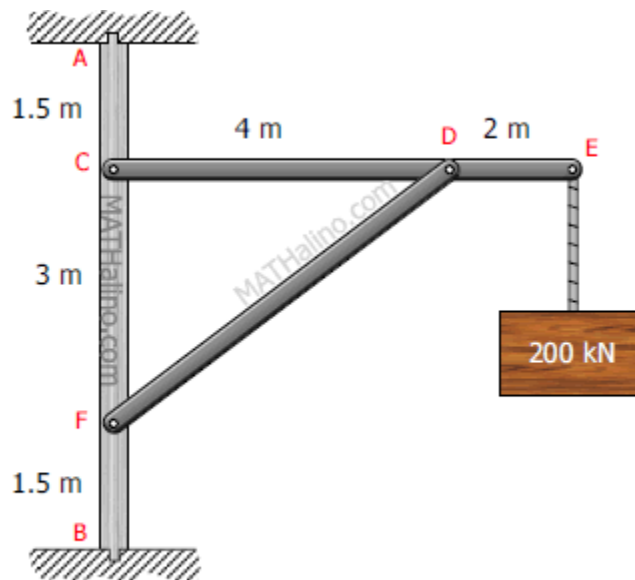

Figure P-348

## Solution 348

Length of DF

$$L_{DF}^2 = 4^2 + 3^2$$

$$L_{DF}^2 = 25$$

$$L_{DF} = 5 \text{ m}$$

Weights of members

$$W_{AB} = 6(5) = 30 \text{ kN}$$

$$W_{CE} = 6(5) = 30 \text{ kN}$$

$$W_{DF} = 5(5) = 25 \text{ kN}$$

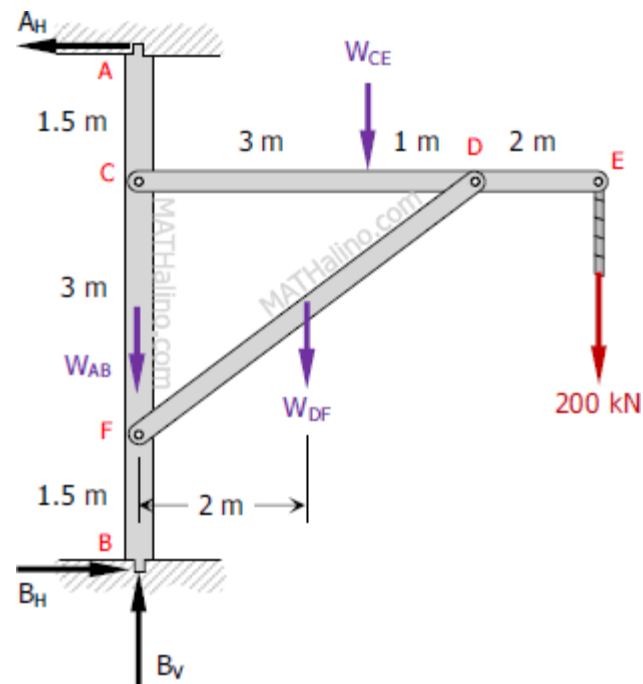

$$\Sigma M_B = 0$$

$$6A_H = 3W_{CE} + 2W_{DF} + 6(200)$$

$$6A_H = 3(30) + 2(25) + 6(200)$$

$$A_H = 223.33 \text{ kN} \quad \text{answer}$$

$$\Sigma F_H = 0$$

$$B_H = A_H$$

$$B_H = 223.33 \text{ kN} \quad \text{answer}$$

$$\Sigma F_V = 0$$

$$B_V = W_{AB} + W_{CE} + W_{DF} + 200$$

$$B_V = 30 + 30 + 25 + 200$$

$$B_V = 285 \text{ kN} \quad \text{answer}$$

## Problem 349 | Equilibrium of Non-Concurrent Force System

### Problem 349

The truss shown in [Fig. P-349](#) is supported on roller at A and hinge at B. Solve for the components of the reactions.

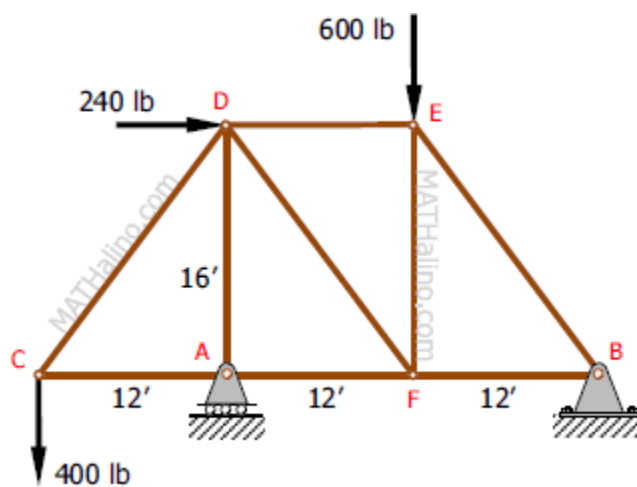

Figure P-349

### Solution 349

$$\Sigma M_B = 0$$

$$24A_V + 16(240) = 36(400) + 12(600)$$

$$A_V = 740 \text{ lb} \quad \text{answer}$$

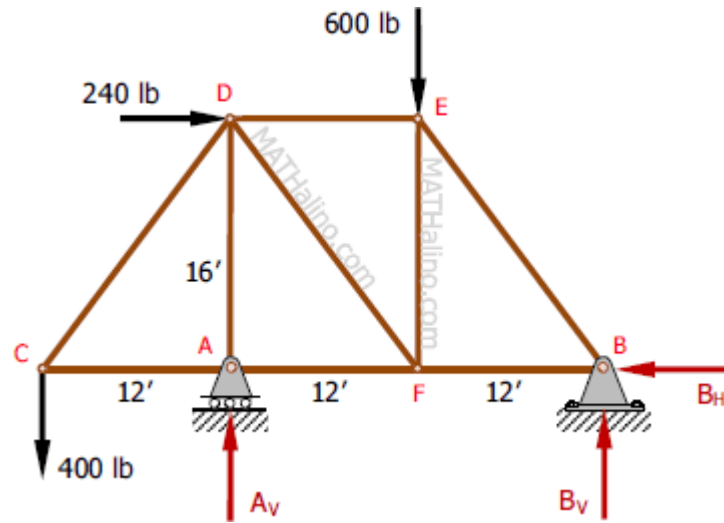

$$\sum M_A = 0$$

$$24B_V + 12(400) = 16(240) + 12(600)$$

$$B_V = 260 \text{ lb} \quad \text{answer}$$

$$\sum F_H = 0$$

$$B_H = 240 \text{ lb} \quad \text{answer}$$

## Problem 350 | Equilibrium of Non-Concurrent Force System

### Problem 350

Compute the total reactions at A and B for the truss shown in [Fig. P-350](#).

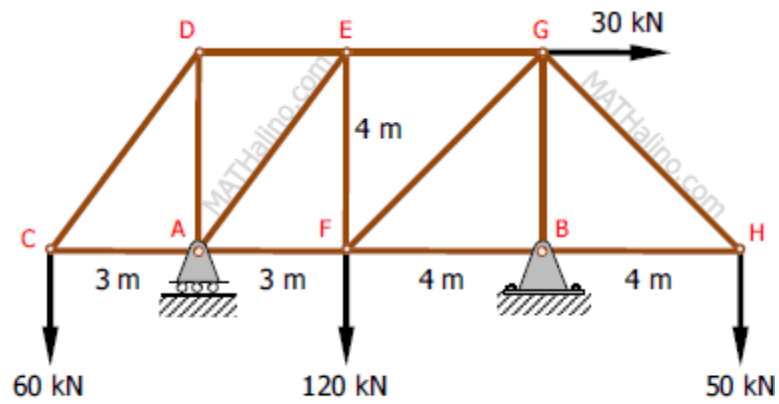

**Figure P-350**

**Solution 350**

$$\sum M_B = 0$$

$$7R_A + 4(30) + 4(50) = 10(60) + 4(120)$$

$$R_A = 108.57 \text{ kN} \quad \text{answer}$$

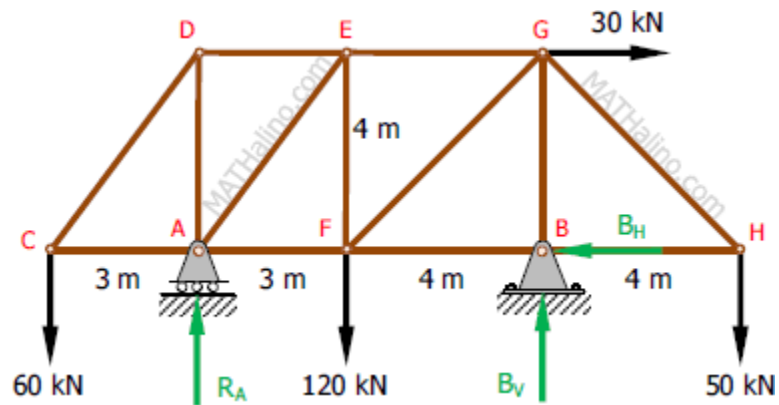

$$\sum M_A = 0$$

$$7B_V + 3(60) = 3(120) + 4(30) + 11(50)$$

$$B_V = 121.43 \text{ kN}$$

$$\sum t_H = 0$$

$$B_H = 30 \text{ kN}$$

$$R_B = \sqrt{B_H^2 + B_V^2} = \sqrt{30^2 + 121.43^2}$$

$$R_B = 125.08 \text{ kN}$$

$$\tan \theta_{Bx} = \frac{B_V}{B_H} = \frac{121.43}{30}$$

$$\theta_{Bx} = 76.12^\circ$$

Thus,  $R_B = 125.08 \text{ kN}$  up to the left at  $76.12^\circ$  from horizontal. *answer*

## Problem 351 | Equilibrium of Non-Concurrent Force System

### Problem 351

The beam shown in [Fig. P-351](#) is supported by a hinge at A and a roller on a 1 to 2 slope at B. Determine the resultant reactions at A and B.

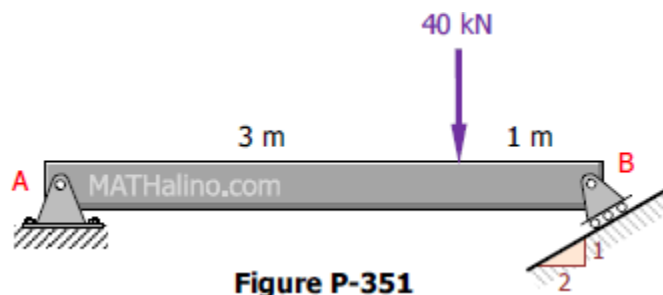
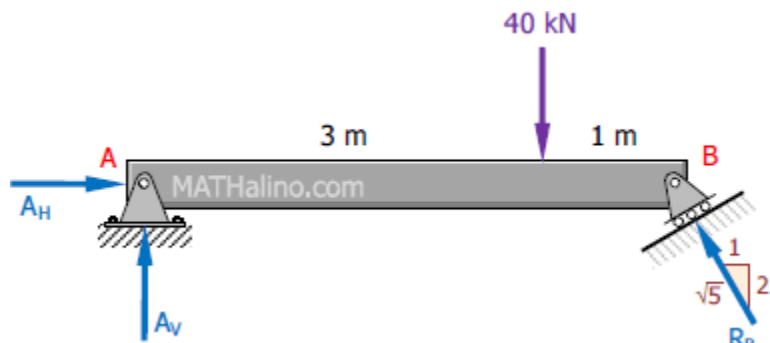

Figure P-351

### Solution 351

$$\sum M_A = 0$$

$$4\left(\frac{2}{\sqrt{5}}R_B\right) = 3(40)$$



$$R_B = 33.54 \text{ kN}$$

$$\Sigma M_B = 0$$

$$4A_V = 1(40)$$

$$A_V = 10 \text{ kN}$$

$$\Sigma F_H = 0$$

$$A_H = \frac{1}{\sqrt{5}}R_B = \frac{1}{\sqrt{5}}(33.54)$$

$$A_H = 15 \text{ kN}$$

$$R_A = \sqrt{A_H^2 + A_V^2} = \sqrt{15^2 + 10^2}$$

$$R_A = 18.03 \text{ kN}$$

$$\tan \theta_{Ax} = \frac{A_V}{A_H} = \frac{10}{15}$$

$$\theta_{Ax} = 33.69^\circ$$

Thus,  $R_A = 18.03 \text{ kN}$  up to the right at  $33.69^\circ$  from horizontal. *answer*

### Another Solution

From [Equilibrium of Concurrent Force System](#), three coplanar forces in equilibrium are concurrent.

$$\frac{y}{1} = \frac{2}{1}$$

$$y = 2 \text{ m}$$

$$\tan \theta_{Ax} = \frac{y}{3}$$

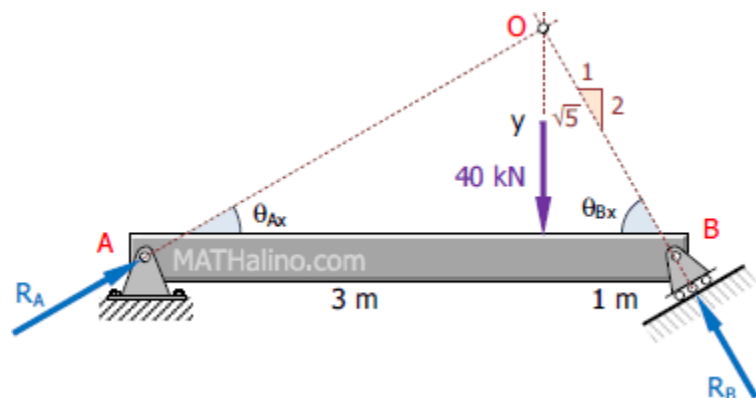

$$\tan \theta_{Ax} = \frac{2}{3}$$

$$\theta_{Ax} = 33.69^\circ \quad \text{okay}$$

$$\tan \theta_{Bx} = \frac{2}{1}$$

$$\theta_{Bx} = 63.43^\circ$$

$$\alpha = 90^\circ - \theta_{Ax} = 56.31^\circ$$

$$\beta = 90^\circ - \theta_{Bx} = 26.57^\circ$$

$$\phi = \theta_{Ax} + \theta_{Bx} = 97.12^\circ$$

$$\frac{R_A}{\sin \beta} = \frac{R_B}{\sin \alpha} = \frac{40}{\sin \phi}$$

$$\frac{R_A}{\sin 26.57^\circ} = \frac{R_B}{\sin 56.31^\circ} = \frac{40}{\sin 97.12^\circ}$$

$$R_A = 18.03 \text{ kN} \quad \text{okay}$$

$$R_B = 33.54 \text{ kN} \quad \text{okay}$$

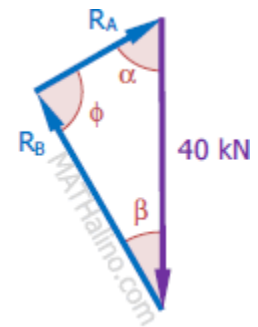

## Problem 352 | Equilibrium of Non-Concurrent Force System

- [beam](#)
- [beam reaction](#)
- [equilibrium](#)
- [non-concurrent forces](#)
- [non-parallel forces](#)
- [pulley](#)

### Problem 352

A pulley 4 ft in diameter and supporting a load 200 lb is mounted at B on a horizontal beam as shown in [Fig. P-352](#). The beam is supported by a hinge at A and rollers at C. Neglecting the

weight of the beam, determine the reactions at A and C.

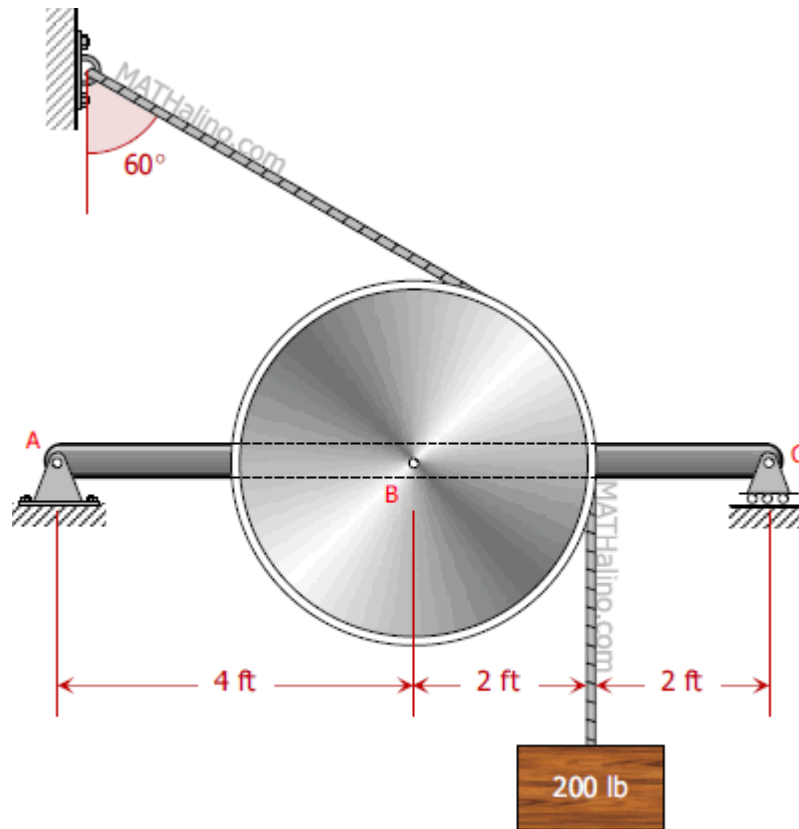

Figure P-352

**Solution 352**

From FBD of pulley

$$T = 200 \text{ lb}$$

$$\Sigma F_V = 0$$

$$B_V + T \sin 30^\circ = 200$$

$$B_V + 200 \sin 30^\circ = 200$$

$$B_V = 100 \text{ lb}$$

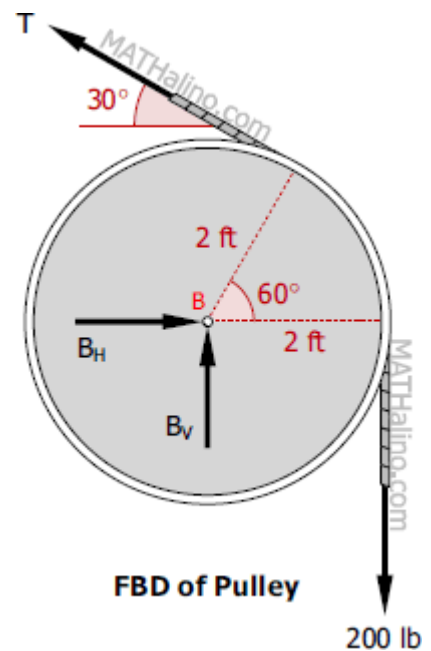

$$\Sigma F_H = 0$$

$$B_H = T \cos 30^\circ$$

$$B_H = 200 \cos 30^\circ$$

$$B_H = 173.20 \text{ lb}$$

**From FBD of beam**

$$\Sigma M_A = 0$$

$$8R_C = 4B_V$$

$$8R_C = 4(100)$$

$$R_C = 50 \text{ lb} \quad \text{answer}$$

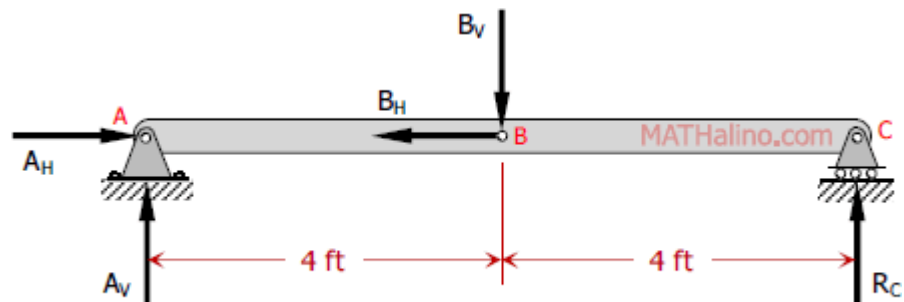

**FBD of Beam**

$$\Sigma M_C = 0$$

$$8A_V = 4B_V$$

$$8A_V = 4(100)$$

$$A_V = 50 \text{ lb}$$

$$\Sigma F_H = 0$$

$$A_H = B_H$$

$$A_H = 173.20 \text{ lb}$$

$$R_A = \sqrt{A_H^2 + A_V^2}$$

$$R_A = \sqrt{173.20^2 + 50^2}$$

$$R_A = 180.27 \text{ lb}$$

$$\tan \theta_{Ax} = \frac{A_V}{A_H}$$

$$\tan \theta_{Ax} = \frac{50}{173.20}$$

$$\theta_{Ax} = 16.1^\circ$$

Thus,  $R_A = 180.27 \text{ lb}$  up to the right at  $16.1^\circ$  from horizontal. *answer*

## Problem 353 | Equilibrium of Non-Concurrent Force System

### Problem 353

The forces acting on a 1-m length of a dam are shown in [Fig. P-353](#). The upward ground reaction varies uniformly from an intensity of  $p_1 \text{ kN/m}$  to  $p_2 \text{ kN/m}$  at B. Determine  $p_1$  and  $p_2$  and also the horizontal resistance to sliding.

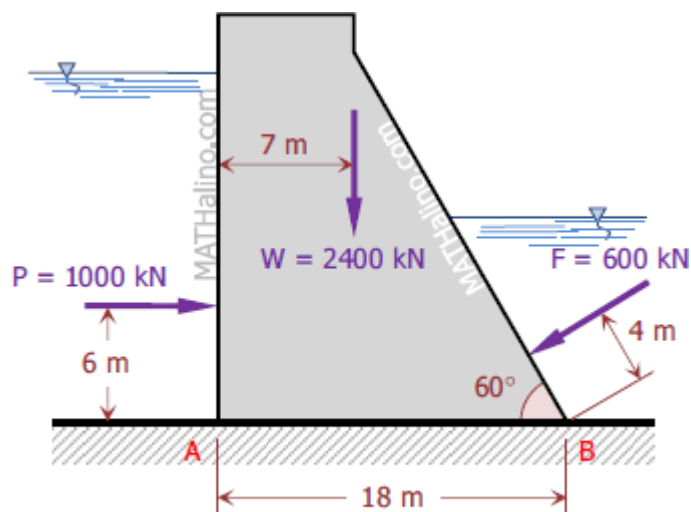

Figure P-353

### Solution 353

Horizontal resistance to sliding

$$\Sigma F_H = 0$$

$$R_x + F \sin 30^\circ = 1000$$

$$R_x + 600 \sin 30^\circ = 1000$$

$$R_x = 700 \text{ kN} \quad \text{answer}$$

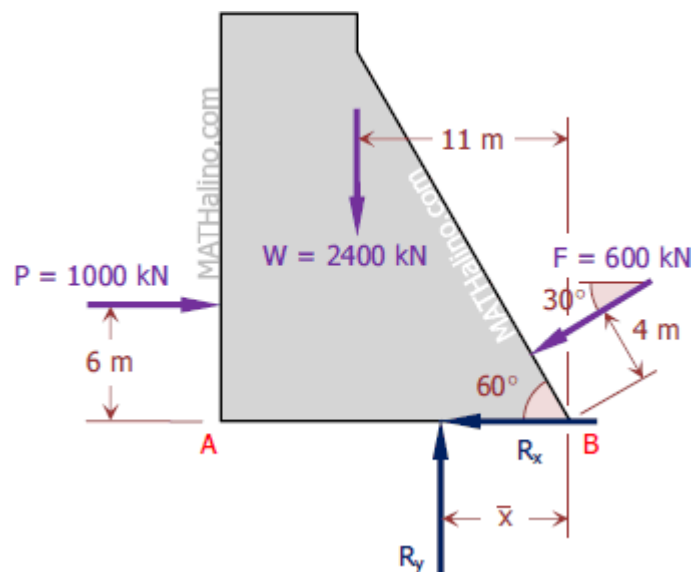

$$\Sigma F_V = 0$$

$$R_y = W + F \sin 30^\circ$$

$$R_y = 2400 + 600 \sin 30^\circ$$

$$R_y = 2700 \text{ kN}$$

Righting moment

$$M_R = 11(2400) + 4(600)$$

$$M_R = 28800 \text{ kN} \cdot \text{m}$$

Overtuning moment

$$M_O = 6(1000)$$

$$M_O = 6000 \text{ kN} \cdot \text{m}$$

$$\Sigma M_B = 0$$

$$\bar{x} R_y = M_B - M_O$$

$$\bar{x}(2700) = 28\,800 - 6000$$

$$\bar{x} = 8.44 \text{ m to the left of B}$$

Eccentricity

$$e = \frac{1}{2}B - \bar{x} = \frac{1}{2}(18) - 8.44$$

$$e = 0.56 \text{ m}$$

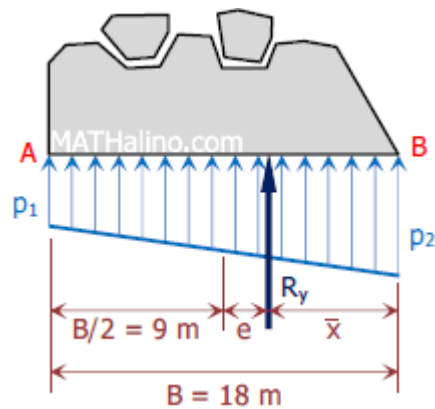

Foundation pressure (See [Dams at CE Review](#) for more information)

$$p = \frac{R_y}{B} \left( 1 \pm \frac{6e}{B} \right)$$

$$p_1 = \frac{2700}{18} \left[ 1 - \frac{6(0.59)}{18} \right] = 122 \text{ kN/m} \quad \text{answer}$$

$$p_2 = \frac{2700}{18} \left[ 1 + \frac{6(0.59)}{18} \right] = 178 \text{ kN/m} \quad \text{answer}$$

Related post: [Resultant of forces in gravity dam](#)

## Problem 354 | Equilibrium of Non-Concurrent Force System

- [equilibrium](#)
- [non-concurrent forces](#)
- [non-parallel forces](#)
- [truss](#)
- [truss reaction](#)

### Problem 354

Compute the total reactions at A and B on the truss shown in Fig. P-354.

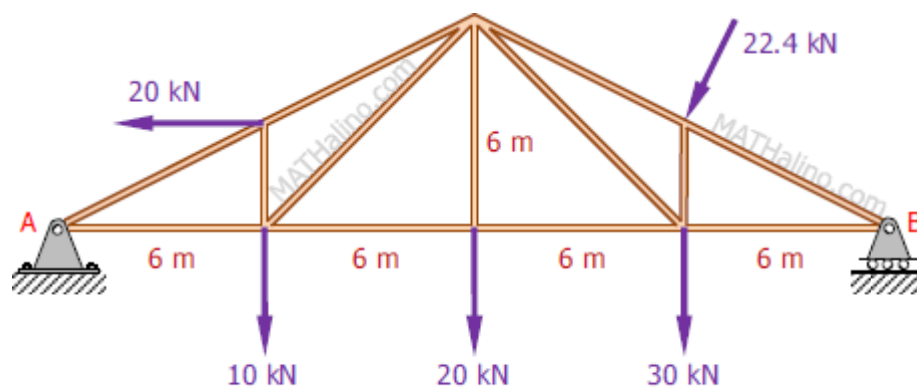

Figure P-354

### Solution 354

$$\Sigma M_A = 0$$

$$24R_B + 3(20) + 3\left(\frac{1}{\sqrt{5}}\right)(22.4) = 18\left(\frac{2}{\sqrt{5}}\right)(22.4) + 18(30) + 12(20) + 6(10)$$

$$R_B = 46.27 \text{ kN} \quad \text{answer}$$

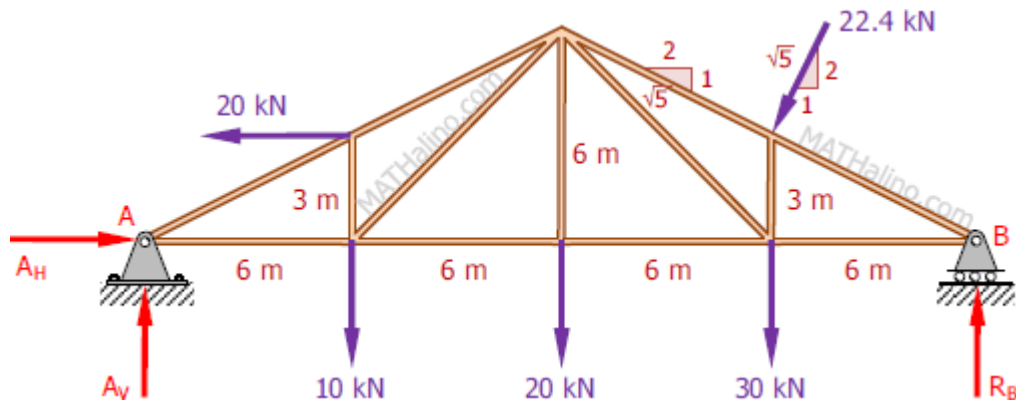

$$\Sigma M_B = 0$$

$$24A_V = 3(20) + 3\left(\frac{1}{\sqrt{5}}\right)(22.4) + 6\left(\frac{2}{\sqrt{5}}\right)(22.4) + 6(30) + 12(20) + 18(10)$$

$$A_V = 33.76 \text{ kN}$$

$$\Sigma F_H = 0$$

$$A_H = 20 + \frac{1}{\sqrt{5}}(22.4)$$

$$A_H = 30.02 \text{ kN}$$

$$R_A = \sqrt{A_H^2 + A_V^2}$$

$$R_A = \sqrt{30.02^2 + 33.76^2}$$

$$R_A = 45.18 \text{ kN}$$

$$\tan \theta_{Ax} = \frac{A_V}{A_H}$$

$$\tan \theta_{Ax} = \frac{33.76}{30.02}$$

$$\tan \theta_{Ax} = 48.36^\circ$$

Thus,  $R_A = 45.18 \text{ kN}$  up to the right at  $48.36^\circ$  from horizontal. *answer*

# Problem 355 | Equilibrium of Non-Concurrent Force System

- [equilibrium](#)
- [fink truss](#)
- [non-concurrent forces](#)
- [non-parallel forces](#)
- [reaction at the support](#)
- [sloping support](#)
- [support reaction](#)
- [truss](#)
- [truss reaction](#)

## Problem 355

Determine the reactions at A and B on the Fink truss shown in [Fig. P-355](#). Members CD and FG are respectively perpendicular to AE and BE at their midpoints.

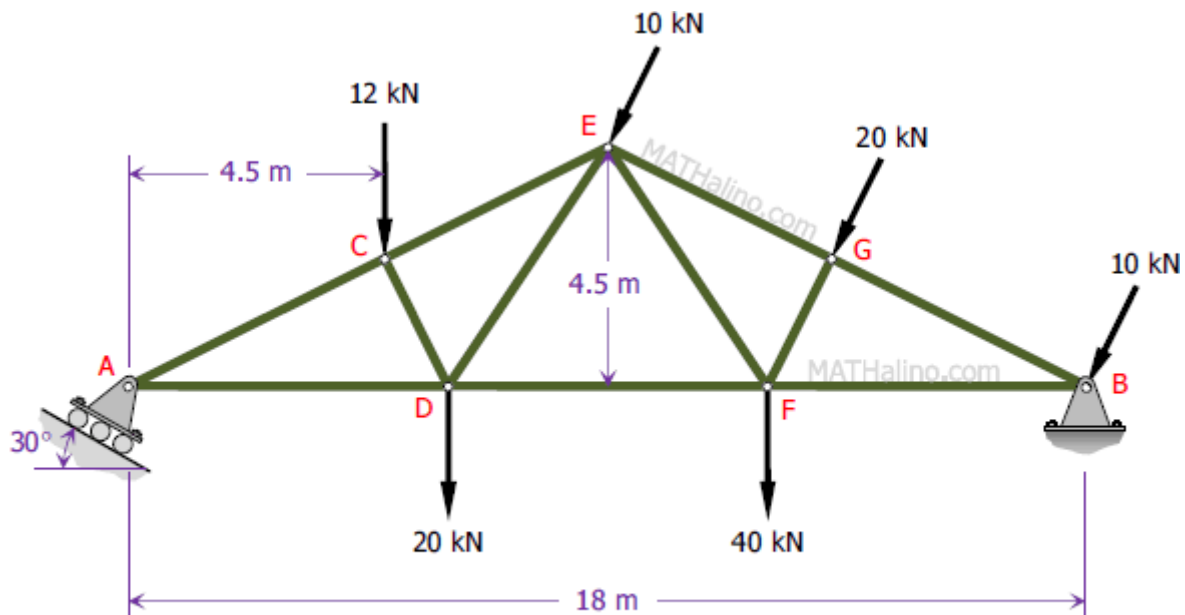

Figure P-355

## Solution 355

$$\tan \theta = 4.5/9$$

$$\theta = 26.56^\circ$$

$$\cos\theta = 4.5/AC$$

$$AC = 4.5/\cos\theta = 4.5/\cos 26.56^\circ$$

$$AC = 5.03 \text{ m}$$

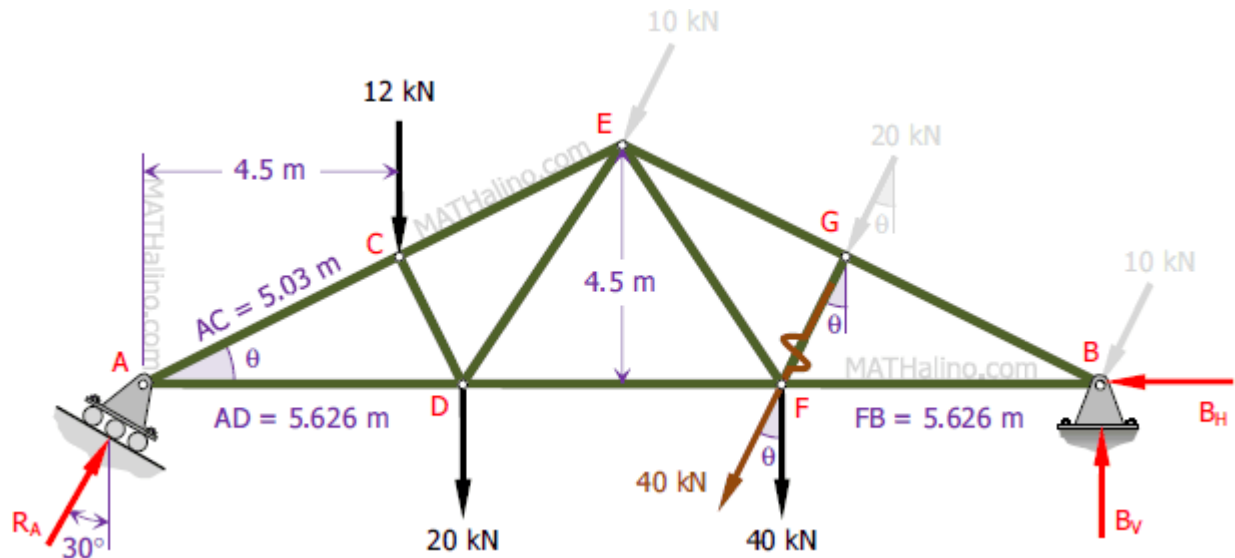

$$\cos\theta = AC/AD$$

$$AD = AC/\cos\theta = 5.03/\cos 26.56^\circ$$

$$AD = 5.626 \text{ m}$$

$$FB = AD$$

$$FB = 5.626 \text{ m}$$

$$\Sigma M_B = 0$$

$$18(R_A \cos 30^\circ) = 12(18 - 4.5) + (40 \cos\theta)(FB) + 40(FB) + 20(18 - AD)$$

$$18(R_A \cos 30^\circ) = 12(13.5) + (40 \cos 26.56^\circ)(5.626) + 40(5.626) + 20(18 - 5.626)$$

$$15.59R_A = 835.81$$

$$R_A = 53.61 \text{ kN} \quad \textit{answer}$$

$$\Sigma F_H = 0$$

$$B_H + 40 \sin \theta = R_A \sin 30^\circ$$

$$B_H + 40 \sin 26.56^\circ = 53.61 \sin 30^\circ$$

$$B_H = 8.92 \text{ kN} \quad \textit{answer}$$

$$\Sigma M_A = 0$$

$$18B_V = 12(4.5) + (40 \cos \theta)(18 - FB) + 40(18 - FB) + 20(AD)$$

$$18B_V = 12(4.5) + (40 \cos 26.56^\circ)(18 - 5.626) + 40(18 - 5.626) + 20(5.626)$$

$$18B_V = 1104.20$$

$$B_V = 61.34 \text{ kN} \quad \textit{answer}$$

## Problem 356 | Equilibrium of Non-Concurrent Force System

- [cantilever truss](#)
- [equilibrium](#)
- [strut](#)
- [support reaction](#)
- [truss](#)
- [truss reaction](#)

### Problem 356

The cantilever truss shown in [Fig. P-356](#) is supported by a hinge at A and a strut BC. Determine the reactions at A and B.

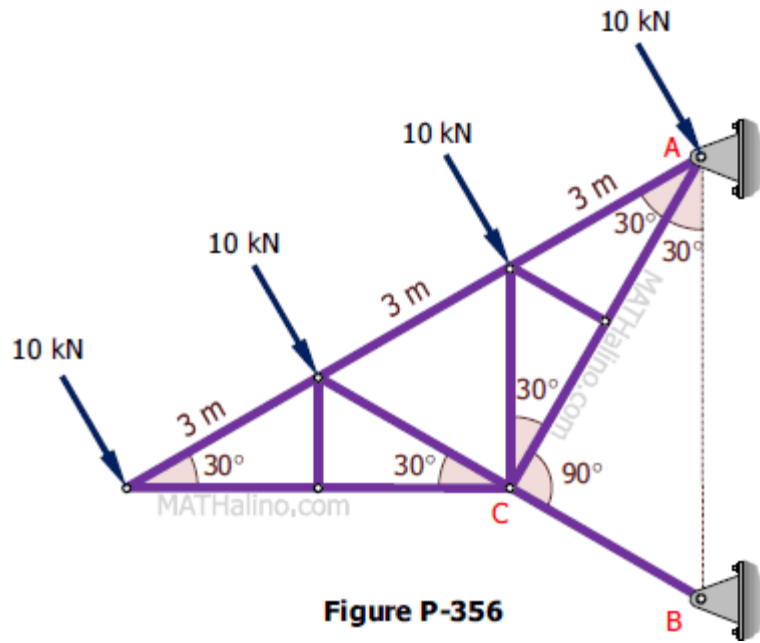

### Solution 356

From right triangles ACD and ACB.

$$\cos 30^\circ = \frac{AC}{6} = \frac{AC}{AB}$$

$$AB = 6 \text{ m}$$

Notice also that triangle ABD is an equilateral triangle of sides 6 m.

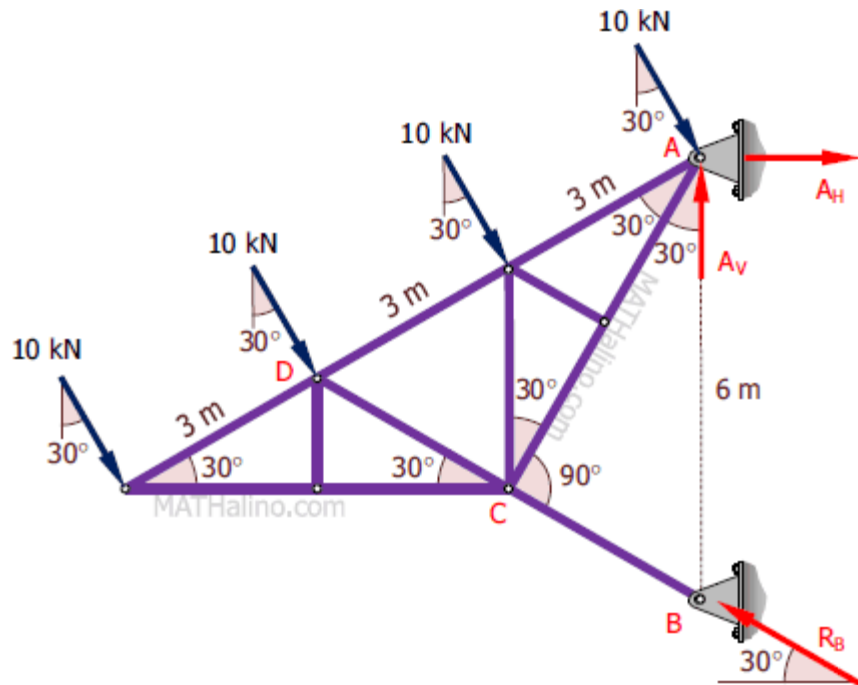

$$\Sigma M_A = 0$$

$$6(R_B \cos 30^\circ) = 3(10) + 6(10) + 9(10)$$

$$R_B = 20\sqrt{3} \text{ kN}$$

$$R_B = 34.64 \text{ kN} \quad \text{answer}$$

$$\Sigma F_H = 0$$

$$A_H + 4(10 \sin 30^\circ) = R_B \cos 30^\circ$$

$$A_H + 4(10 \sin 30^\circ) = 20\sqrt{3} \cos 30^\circ$$

$$A_H = 10 \text{ kN}$$

$$\Sigma F_V = 0$$

$$A_V + R_B \sin 30^\circ = 4(10 \cos 30^\circ)$$

$$A_V + 20\sqrt{3} \sin 30^\circ = 4(10 \cos 30^\circ)$$

$$A_V = 10\sqrt{3} \text{ kN}$$

$$A_V = 17.32 \text{ kN}$$

$$R_A = \sqrt{A_H^2 + A_V^2}$$

$$R_A = \sqrt{10^2 + (10\sqrt{3})^2}$$

$$R_A = 20 \text{ kN}$$

$$\tan \theta_{Ax} = \frac{A_V}{A_H}$$

$$\tan \theta_{Ax} = \frac{10\sqrt{3}}{10}$$

$$\theta_{Ax} = 60^\circ$$

Thus,  $R_A = 20 \text{ kN}$  up to the right at  $60^\circ$  from horizontal. *answer*

## Problem 357 | Equilibrium of Non-Concurrent Force System

### Problem 357

The uniform rod in [Fig. P-357](#) weighs 420 lb and has its center of gravity at G. Determine the tension in the cable and the reactions at the smooth surfaces at A and B.

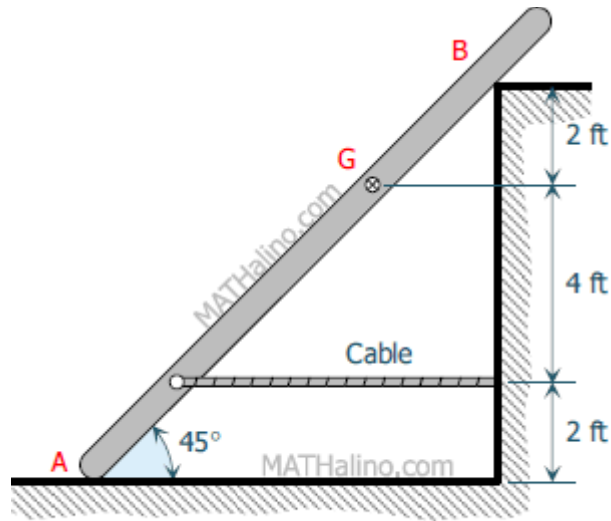
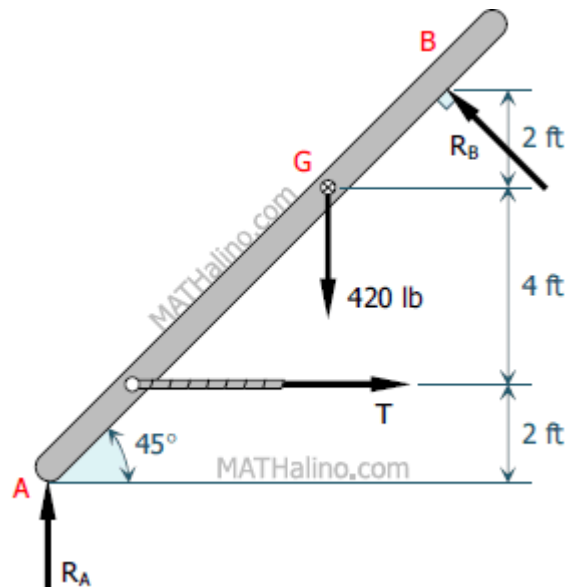

Figure P-357

**Solution 357**

Distance AB

$$AB = \sqrt{8^2 + 8^2} = 8\sqrt{2} \text{ m}$$



$$\sum F_H = 0$$

$$T = R_B \cos 45^\circ$$

$$\Sigma M_A = 0$$

$$2T + 6(420) = 8\sqrt{2}R_B$$

$$2T + 2520 = 8\sqrt{2}R_B$$

$$T + 1260 = 4\sqrt{2}R_B$$

$$R_B \cos 45^\circ + 1260 = 4\sqrt{2}R_B$$

$$4.9497R_B = 1260$$

$$R_B = 254.56 \text{ lb} \quad \textit{answer}$$

$$T = 254.56 \cos 45^\circ$$

$$T = 180 \text{ lb} \quad \textit{answer}$$

$$\Sigma F_V = 0$$

$$R_A + R_B \sin 45^\circ = 420$$

$$R_A + 254.56 \sin 45^\circ = 420$$

$$R_A = 240 \text{ lb} \quad \textit{answer}$$

## Problem 358 | Equilibrium of Non-Concurrent Force System

### Problem 358

A bar AE is in equilibrium under the action of the five forces shown in [Fig. P-358](#). Determine P, R, and T.

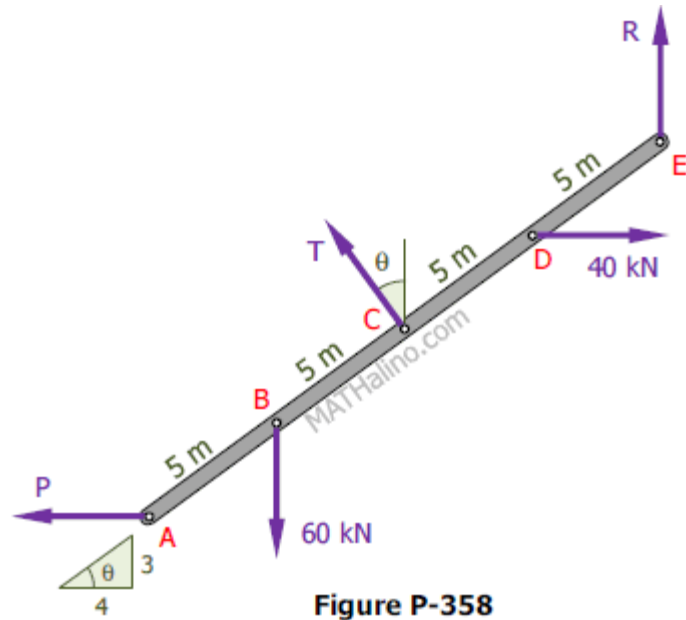

Figure P-358

**Solution 358**

$$\sum F_V = 0$$

$$\frac{4}{5}T + R = 60$$

$$R = 60 - \frac{4}{5}T$$

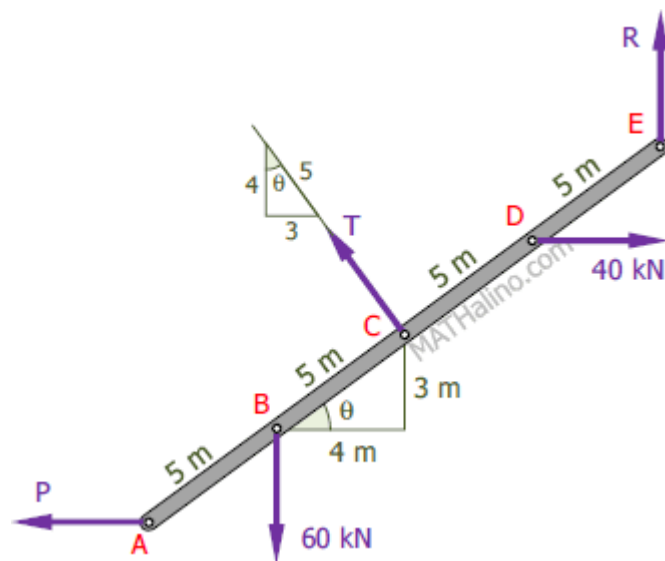

$$\Sigma M_A = 0$$

$$10T + 4(4)R = 4(60) + 3(3)(40)$$

$$10T + 16R = 600$$

$$5T + 8R = 300$$

$$5T + 8(60 - \frac{4}{5}T) = 300$$

$$-\frac{7}{5}T + 480 = 300$$

$$\frac{7}{5}T = 180$$

$$T = 128.57 \text{ kN up to the left} \quad \textit{answer}$$

$$R = 60 - \frac{4}{5}(128.57)$$

$$R = -42.86 \text{ kN}$$

$$R = 42.86 \text{ kN downward} \quad \textit{answer}$$

$$\Sigma F_H = 0$$

$$P + \frac{3}{5}T = 40$$

$$P + \frac{3}{5}(128.57) = 40$$

$$P = -37.14 \text{ kN}$$

$$P = 37.14 \text{ kN to the right} \quad \textit{answer}$$

## Problem 359 | Equilibrium of Non-Concurrent Force System

### Problem 359

A 4-m bar of negligible weight rests in a horizontal position on the smooth planes shown in [Fig. P-359](#). Compute the distance  $x$  at which load  $T = 10 \text{ kN}$  should be placed from point B to keep

the bar horizontal.

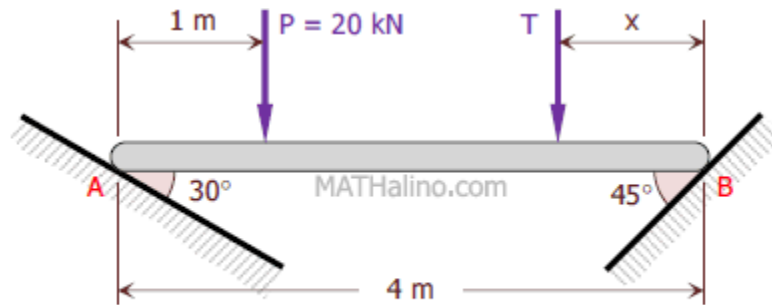
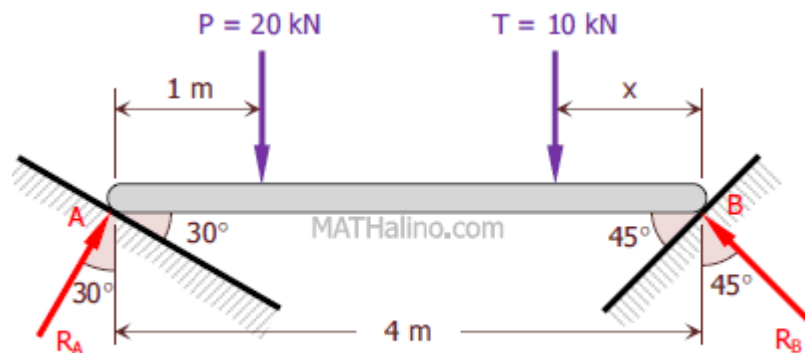

Figure P-359, P-360, and P-361

Solution 359



Free Body Diagram

From the Force Polygon

$$\frac{R_A}{\sin 45^\circ} = \frac{20 + 10}{\sin 105^\circ}$$

$$R_A = 21.96 \text{ kN}$$

From the Free Body Diagram

$$\Sigma M_B = 0$$

$$4(R_A \cos 30^\circ) = 20(3) + 10x$$

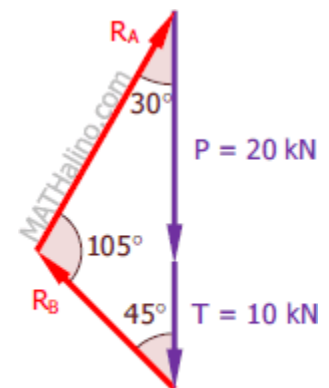

Force Polygon

$$4(21.96 \cos 30^\circ) = 20(3) + 10x$$

$$10x = 16.072$$

$$x = 1.61 \text{ m} \quad \text{answer}$$

## Problem 360 | Equilibrium of Non-Concurrent Force System

### Problem 360

Referring to [Problem 359](#), what value of  $T$  acting at  $x = 1 \text{ m}$  from  $B$  will keep the bar horizontal.

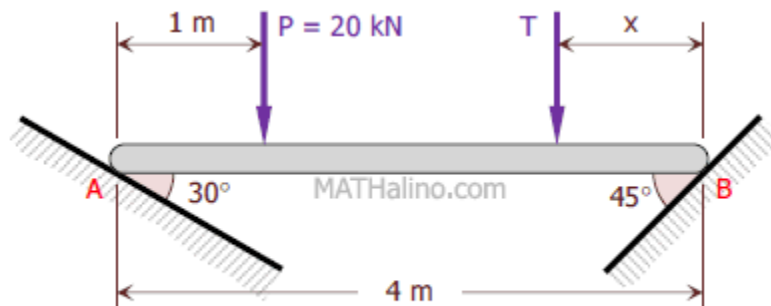
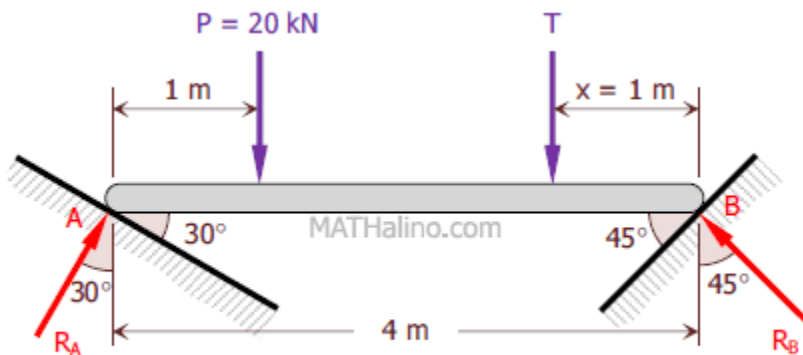

Figure P-359, P-360, and P-361

### Solution 360



Free Body Diagram

From the Force Polygon

$$\frac{R_A}{\sin 45^\circ} = \frac{20 + T}{\sin 105^\circ}$$

$$R_A = 0.732(20 + T)$$

$$R_A = 14.641 + 0.732T$$

From the Free Body Diagram

$$\sum M_B = 0$$

$$4(R_A \cos 30^\circ) = 3(20) + 1(T)$$

$$4(14.641 + 0.732T) \cos 30^\circ = 60 + T$$

$$50.7179 + 2.5357T = 60 + T$$

$$1.5357T = 9.2821$$

$$T = 6.04 \text{ kN} \quad \text{answer}$$

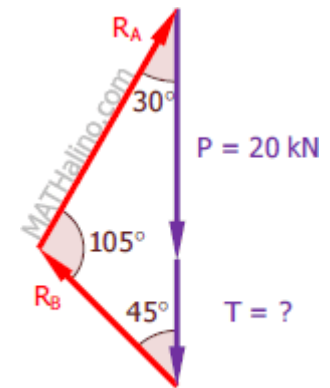

Force Polygon

## Problem 361 | Equilibrium of Non-Concurrent Force System

### Problem 361

Referring to [Problem 359](#), if  $T = 30 \text{ kN}$  and  $x = 1 \text{ m}$ , determine the angle  $\theta$  at which the bar will be inclined to the horizontal when it is in a position of equilibrium.

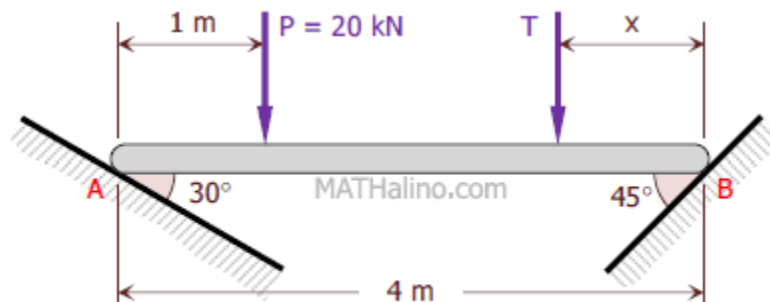
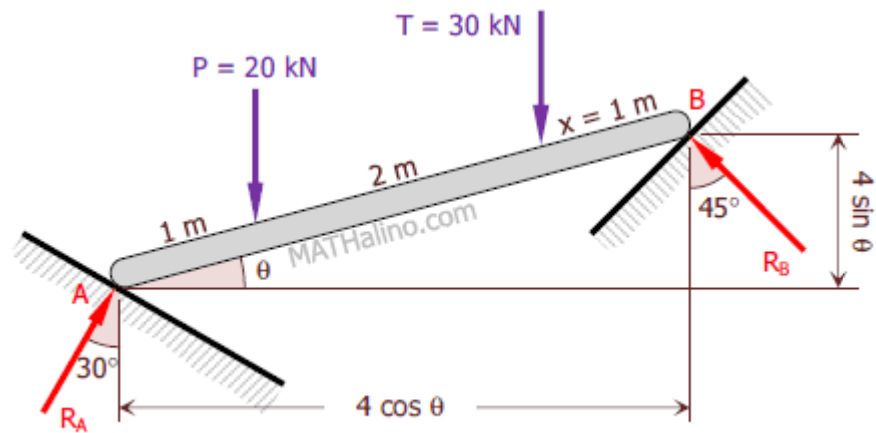

Figure P-359, P-360, and P-361

Solution 361



Free Body Diagram

From the Force Polygon

$$\frac{R_A}{\sin 45^\circ} = \frac{20 + 30}{\sin 105^\circ}$$

$$R_A = 36.60 \text{ kN}$$

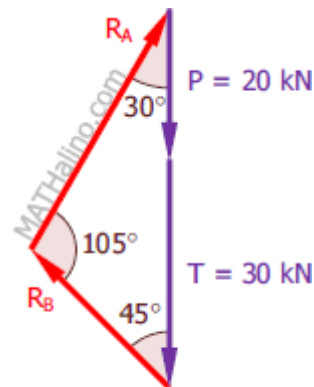

Force Polygon

From the Free Body Diagram

$$\sum M_B = 0$$

$$(4 \cos \theta)(R_A \cos 30^\circ) = (4 \sin \theta)(R_A \sin 30^\circ) + (3 \cos \theta)(20) + (1 \cos \theta)(30)$$

$$(4 \cos \theta)(36.60 \cos 30^\circ) = (4 \sin \theta)(36.60 \sin 30^\circ) + (3 \cos \theta)(20) + (1 \cos \theta)(30)$$

$$126.7861 \cos \theta = 73.2 \sin \theta + 60 \cos \theta + 30 \cos \theta$$

$$36.7861 \cos \theta = 73.2 \sin \theta$$

$$\frac{36.7861}{73.2} = \frac{\sin \theta}{\cos \theta}$$

$$\tan \theta = 0.5025423497$$

$$\theta = 26.68^\circ \quad \text{answer}$$